

Entellisys™

Low-Voltage Switchgear Application Guide



Contents

Section	Page
1 Introduction	1
2 General Description	3
3 System Architecture	5
4 Minimizing Potential Exposure to Arc Flash Energy	11
5 EntelliGuard Breaker	17
6 EntelliGuard Messenger	23
7 Protection	25
8 Metering	39
9 Events and Diagnostics	45
10 Digital I/O	51
11 Control	53
12 EntelliGuard Preventative Maintenance	55
13 User Interface - HMI	57
14 Remote Communication	63
15 Design Considerations	65
16 Layout and Sizing	69
17 Appendices	93
A. Guide Form Specification	93
B. Type Tests	101
C. Standard and Optional Features	103
D. Time Current Curves	105

Entellisys™ Low-Voltage Switchgear

Section 1. Introduction

Since electricity was first harnessed, protecting circuits against faults and overloads has been a persistent challenge. Circuit protection technology has advanced over the years, with today's modern fuses, bimetallic trips, magnetic trips, and powerful electronic trips providing a wide range of choices. However, from the simplest fuse to the most complex digital trip, all of these devices have a common limit; all are only able to consider the current in the conductors they directly protect. Because of this limitation, these mechanisms are oblivious to the larger systems and changing environments within which they operate. All modern trip systems can only react to what they know—the current magnitude and time.

Entellisys Low-Voltage Switchgear is the first circuit-protection technology that overcomes this limitation. The Entellisys “Single-Processor Concept” bases control of every circuit breaker in the switchgear upon what is best for the entire system under the exact conditions in the system at that moment. Each trip function is no longer limited to the current information available at its particular circuit. With Entellisys, each circuit breaker is controlled with full information about every current, voltage, and circuit breaker in the switchgear.

Entellisys is the first system to provide the power of knowledge about the entire switchgear lineup. This power can be used by the engineer to improve protection, by the installing contractor to shorten installation time, by the maintenance manager to save maintenance costs, and by the owner to adapt the equipment to the dynamic needs of the facility. Entellisys helps to reduce costs, shorten schedules, and increase reliability throughout the process of designing, installing, maintaining, and owning your low-voltage power distribution switchgear.

This application guide will introduce you to the power of Entellisys and how it can help you to deliver electrical power within your facility more reliably than ever possible before.

Welcome to the world of Entellisys.

Notes

Entellisys Low-Voltage Switchgear

Section 2. General Description

Entellisys low-voltage switchgear provides protection, control, and monitoring in a flexible package that will change the way you think about switchgear. All of this capability is integrated into industrial-duty equipment built to ANSI standards and uses 100% rated EntelliGuard low-voltage power circuit breakers. Entellisys low-voltage switchgear is built upon the same design as the rugged AKD architecture, with almost 60 years of proven reliability. The Entellisys equipment design is based on the AKD-10 structure. EntelliGuard low-voltage power circuit breakers are an extension of the robust WavePro™ design, with years of experience in all types of switchgear environments.

Entellisys low-voltage switchgear is available with the following maximum nominal ratings:

- 600 volts ac
- 5000 amps ac
- 50/60 Hz
- 200 kA symmetrical short circuit interrupting

Entellisys switchgear is designed to have more margin within its ratings to provide maximum continuity of service for those applications subject to severe duty, such as process industries, data centers, healthcare facilities, and power systems requiring continuous operation. It is designed to be operated in an ambient temperature between -30°C and 40°C and is available in indoor construction. The bus sizing is based on temperature rise rather than on current density (as with switchboard construction).

EntelliGuard low-voltage power circuit breakers are available for Entellisys switchgear in six frame sizes: 800A, 1600A, 2000A, 3200A, 4000A and 5000A.

All circuit breakers can be equipped with current limiting fuses. The 800A and 1600A frames are provided with integrally mounted fuses, while a separate fuse carriage is required for 2000A through 5000A type breakers.

Entellisys switchgear houses low-voltage power circuit breakers and the Entellisys system components in single or multiple source configurations. Entellisys switchgear can be applied either as a power distribution unit or as part of a unit substation.

Entellisys switchgear is manufactured in GE's ISO 9001 certified facility in Burlington, Iowa. It complies

with ANSI standards C37.20.1 and NEMA SG-5, and is UL Listed to standard 1558, file no. E76012. The switchgear has been conformance tested according to ANSI C37.51.

ANSI standards require that switchgear operates at the ratings of devices installed. Switchgear short circuit ratings are based on two 30-cycle withstand tests with a 15-second interval between tests, performed at 15% power factor and 635v AC maximum.

GE's Entellisys low-voltage switchgear can help you meet today's challenges for greater productivity, increased operator safety, and improved equipment reliability and maintainability.

Entellisys low-voltage switchgear offers:

- Safety – Human interface located away from the equipment for monitoring, control, and remote racking. Advanced zone protection provides fast fault identification while providing selectivity.
- Reliability – Redundant systems, selective protection, and predictive maintenance data aids in maximizing uptime and minimizing downtime.
- Flexibility – Add or change system functionality with no hardware changes, making it easy to keep the equipment up to date to meet changing needs.

The Entellisys architecture enables the system to provide these unique advantages.

Notes

Entellisys Low-Voltage Switchgear Section 3. System Architecture

Historically, advances in power distribution protection, control, and monitoring have translated into many separate components: circuit breakers with trip units controlling them, meters, PLCs used for control, and any other relays or devices necessary. These solutions force multiple, independent devices to execute multiple, independent actions, not to mention the many wiring terminations required. The outcome is complex systems that result in circuit protection still dependent upon individual devices looking at mere subsets of the available information within a lineup. Thus, protection and selectivity are sub-optimized. Add to that the challenge of linking these many multiple devices to remote locations via communication networks and you have a complex system that is not designed to provide maximum protection, monitoring, and control.

There is a better way.

Entellisys is an integrated switchgear system that uses a single central processing unit (CPU) to perform all of the protection, monitoring, control, communication, and diagnostic functions that could be required for a low-voltage switchgear lineup. Entellisys replaces discrete devices and associated point-to-point wiring that are used to perform these functions in traditionally designed switchgear. The basic system uses a structured hardware design consisting of the CPU, a digital communication network, current sensors, device electronics for the circuit breaker, control power, voltage transformers, and an HMI (human-machine interface). Redundant CPUs, communication networks, and critical devices are standard, improving the layers of backup when

compared to traditional switchgear. Figure 3.1 depicts the Entellisys system architecture.

All Entellisys components are designed to be located within the low-voltage switchgear line-up. Following is a description of the major Entellisys system components.

EntelliGuard Circuit Breaker

The EntelliGuard circuit breaker is built upon the same proven design as the WavePro metal-frame low-voltage power circuit breaker, except that it has no internal trip unit or internal current sensors. The circuit breaker is a non-automatic device and the current sensors and electronics are attached to the breaker cubicle. This allows all breakers of a given frame size to be interchangeable regardless of the circuit's requirements for trip rating and overcurrent trip characteristics.

The EntelliGuard circuit breaker is an ANSI-rated, UL 1066-listed draw-out circuit breaker. The circuit breaker is supplied in two forms, manually or electrically operated. Electrically operated breakers can be closed, opened, and tripped by way of Entellisys. Manually operated breakers are only tripped by Entellisys. The EntelliGuard circuit breaker is available in 800, 1600, 2000, 3200, 4000, and 5000 ampere frame sizes with short-circuit interrupting ratings from 30kA to 200kA. Accessories for the EntelliGuard circuit breaker include a bell alarm with mechanical lockout (local lockout) and a network interlock (for electrically operated breakers only). Details of the EntelliGuard circuit breaker, operation, and accessories are covered in Section 5.

Figure 3.1

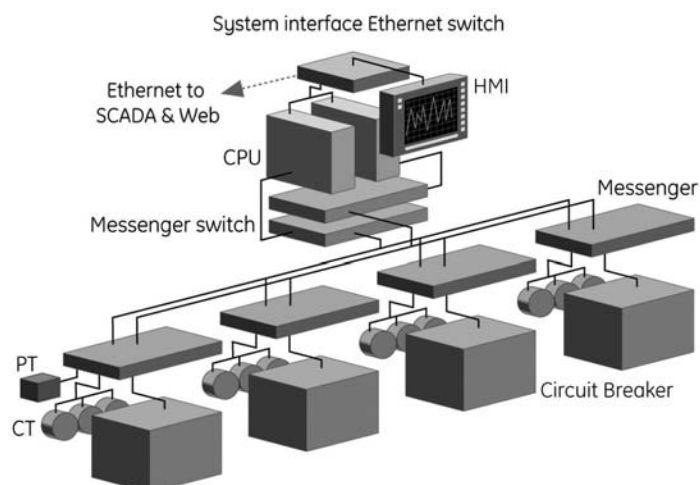

EntelliGuard Messenger

The EntelliGuard Messenger is the electronic interface between the Entellisys system's central processing units and the EntelliGuard circuit breaker. The primary duties of the Messenger are to function as an analog-to-digital converter of voltage and current signals at the circuit breaker, communicate the raw electrical data to the system's central processing units, receive operating instructions from the central processing units, and execute those instructions on the EntelliGuard circuit breaker. The Messenger also provides backup instantaneous and overload protection in the rare case communication is lost with both CPUs. Under these conditions the Messenger is powered by the current sensors, similar to trip units in traditional low-voltage switchgear. Details of the specific functions of the EntelliGuard Messenger are covered in Section 6.

Current Sensors

Each breaker cubicle is furnished with a set of three-phase current sensors. The current sensors have primary ratings of 150, 400, 800, 1600, 2000, 3200, 4000, and 5000 amps. The secondary rating of all current sensors is 600 milli-amps. The analog output of the current sensor is connected to the EntelliGuard Messenger via a plug-in connector. All current sensors are provided with built-in open circuit protection so separate open circuit protection and shorting devices are not required. Current sensors rated 150 amps through 2000 amps are designed as a three-phase unit. Current sensors rated 3200 amps through 5000 amps are designed as single-phase units. 150 and 400 amp current sensors are also provided with a clamp circuit to limit voltage on the Messenger electronics during high magnitude faults.

Current sensors can be located on the upper or lower primary disconnects in the circuit breaker cubicle. Location of the current sensor for the standard overcurrent protective functions is not critical but for the more advanced protection functions, such as bus differential, placement of the current sensor becomes more critical. For purposes of standardization, the current sensors for source breakers (transformer secondary breakers, generator breakers, etc.) are located on the source side of the circuit breaker cubicle. This will typically be on the upper primary disconnects but can be on the lower primary disconnects for reverse-fed breakers. Current sensors for feeder breakers will be located

on the load side of the breaker cubicle. Typically, this will be the lower primary disconnects in the cubicle unless the feeder cubicle is reverse-fed.

Potential (Voltage) Transformers

Potential or voltage transformers are used to convert power system level voltages to voltages that can be used by Entellisys. Voltage transformers are supplied in two forms – two units connected in open delta on the primary and secondary or three units connected wye on the primary and secondary. The transformers are rated for either line-to-line voltages (open delta) or line-to-neutral voltages (wye). The secondary voltage of each transformer is 18 volts.

The output of the voltage transformers is connected to at least one EntelliGuard Messenger in the line-up. All other Messengers can reference this voltage for their metering and protective relay functions. This allows the voltage to be sampled at one location but applied to as many breakers in the switchgear line-up as necessary. For a single-source switchgear line-up, the voltage transformers can be connected to the Messenger for the main circuit breaker and all feeder breaker Messengers can be referenced to the voltage at the main circuit breaker Messenger. There is no need to connect the voltage signal to all of the feeder Messengers for individual metering at the feeders.

Likewise for multi-source switchgear line-ups, the voltage for the feeders can be referenced from either main circuit breaker Messenger. In the case of a double-ended switchgear line-up, the feeders on a bus can be referenced to their respective main circuit breaker voltage signals under normal operating conditions. When a main breaker is opened and the tie breaker closed, programming in the Entellisys system can be set to switch the voltage reference to the opposite main breaker. This eliminates the need for bus-connected voltage transformers or complex transfers on the secondary of the voltage transformers to maintain accurate feeder metering.

CPU

The intelligence behind the Entellisys system is the central processing unit (CPU). The CPU processes data from up to 30 circuit breakers within the switchgear line-up and, based on the system programming, will perform the required metering,

protective, and control functions. Inputs to the CPU are the electrical current data from each circuit, voltage data from each power source, status from each circuit breaker (open, closed, tripped, locked-out, closing spring state, breaker primary and secondary disconnect position), and the status of optional Digital I/O (up to 128 points). This information is used by the CPU to determine the low-voltage distribution system configuration and issue any control or protective function instructions to the appropriate circuit breakers via the Messengers.

Internal Communications

Entellisys uses a deterministic communication system to provide the necessary fast, reliable, and predictable transfer of data between the CPU and Messengers. The communication system in Entellisys is structured to yield fixed latency and sub-cycle transmission times between the CPU and all other devices connected to the internal communication system. The overcurrent protective functions in the CPU run at the highest priority and the system is sampling data from each circuit breaker and issuing commands to the breakers every 8.33 milliseconds or every half cycle.

The internal communications network uses commercial, off-the-shelf, Ethernet network switches to connect the Messengers to the CPUs. The network switch has a port for every Messenger so that each circuit breaker cubicle has two dedicated “home runs” back to the CPU. The internal communications

network is a closed system, providing maximum security for the critical protective, control, and metering functions at each circuit breaker.

System Redundancy

Entellisys has redundancy at every key system component to insure operation under the most adverse system and environmental conditions. Starting at the breaker cubicle level, the EntelliGuard Messenger is provided with dual power supply inputs and redundant communication ports. Each communication port is connected to a redundant communication cable that terminates at redundant network communication switches. Each communication switch is connected to a redundant, synchronized central processing unit. Messengers, CPUs, and communication switches are all powered from redundant UPSs fed from dual control power sources through redundant control power transfer relays. Figure 3.2 depicts the multiple levels of redundancy that are standard in Entellisys.

An additional level of redundancy is the backup protection provided by the Messengers in the event both CPUs are not communicating with the Messenger. In this rare case, the Messenger is powered from the current sensors and provides overload and short circuit protection. In other words, in a worse case scenario, the system provides overcurrent protection that is similar to the only protection offered in many traditional switchgear lineups today.

Figure 3.2

Overall System Architecture

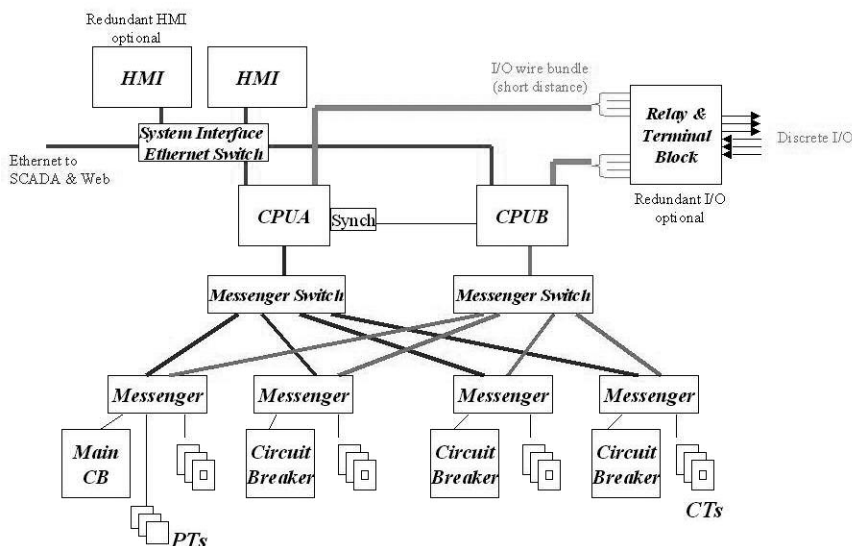

Synchronization

Synchronization between the two central processors (CPUs) is maintained through a hardware Sync Clock on CPU-A and a connection to CPU-B. This keeps both CPUs running in a synchronized manner so that if monitoring or control is switched from one CPU to the other, the execution is seamless.

Control Power System, Including UPS

Switchgear-connected, single-phase control power transformers with 120v AC secondaries supply control power for all of the Entellisys components. Ideally, there should be two control power transformers connected to different power sources, to provide redundant control power. This is straightforward for multiple-source switchgear line-ups where each source (utility or generator) will have a control power transformer. For single-ended line-ups, the redundant control power source can be customer-supplied or another switchgear single-phase control power transformer connected to different phases.

Each 120v AC control power source is connected to a control power transfer relay and the output of each transfer relay is connected to a UPS. Each UPS is a true VFI (voltage and frequency independent) on-line double conversion high performance device. All Entellisys components are powered from the output of the two UPSs except the spring charging motors for the electrically operated circuit breakers. The spring charging motors are connected ahead of the UPS on the output of the control power transfer relay.

HMI (Human-Machine Interface)

The HMI is the system interface providing touch-screen access to screens for viewing the status of the Entellisys system itself (system and component “health”), the distribution system status (metering data for each circuit breaker, breaker status), protective settings for each circuit breaker (over-current protection, protective relays), alarm settings and status (for each circuit breaker and for the system), sequence-of-events log, and captured waveforms. The standard HMI is located within the switchgear line-up, in an auxiliary cubicle. A redundant HMI can also be installed for larger switchgear line-ups that may be split but located within close proximity of each other. Once the system is programmed, the HMI is not a critical component to allow Entellisys to provide its protective functions.

Entellisys uses password protection to provide various levels of access to system information. The owner can set up different levels of access ranging from a “Guest” level, where only metering and status information can be viewed, to an “Administrator” level, which allows access to breaker protection settings and control of the circuit breakers. Customized user groups can also be defined that will give each group specific permissions to view and/or access items such as breaker control, viewing the sequence of events log, viewing settings, changing settings, etc.

Near-Gear HMI

If local monitoring and control at the equipment is not desired, then a near-gear HMI may be used. The near-gear HMI has the same capabilities as the local HMI and can be positioned up to 300 feet (wiring distance) from the switchgear and CPU. One application for the near-gear HMI would be to move the control and monitoring point outside the hazardous arc flash zone.

Remote HMI and External Communications

Additional monitoring and control stations can be added to the system by adding remote HMI software to a personal computer that is or can be installed on the owner’s local area network. Up to eight local and remote HMIs can communicate with Entellisys at any given time.

All remote communications takes place at the HMI level and has no impact on the performance of the closed internal communications level between the EntelliGuard Messengers and the central processing units. No external communications are permitted to take place with the CPUs, thereby insuring the security of the operating system.

The physical connection for remote communication is at the system interface Ethernet switch between the CPUs and the HMI. Additional ports on this 8-port switch allow up to five external connections using CAT5 cable. An optional 9-port hub is available to allow external communication via fiber optic cable. Up to four local HMIs can be connected to the system interface Ethernet switch, and a LAN connection can support multiple remote HMIs. A local HMI can block out other HMIs (local or remote) from controlling the circuit breakers in the switchgear. This provides secure control for the breakers during any maintenance operations.

Connections to remote HMIs on a LAN can be through a VPN (virtual private network) firewall device. The VPN only allows pre-defined remote IP addresses to have access to the system, further enhancing the security of Entellisis.

Entellisis can also be interfaced with external monitoring and control systems via remote communications. Entellisis communicates with external systems via Modbus TCP protocol, providing an open, common language for interfacing with SCADA, building automation, and process systems.

Digital I/O

Entellisis can interface with external monitoring and control systems in several ways. The most conventional means is by way of digital inputs and outputs. Up to 128 I/O points can be defined for use in monitoring and control systems. Digital I/O can be provided in non-redundant or redundant configurations. Digital I/O is designed to accept and provide dry contact operations. A more detailed discussion of Digital I/O occurs in Section 10.

Expansion Capabilities

Entellisis switchgear is designed to be easily modified or expanded to handle change in or increased loading.

Metering functions, system-wide waveform capture and most protection can be easily changed with software upgrades to the CPUs, requiring no additional hardware. Consequently it is possible to add features to one CPU while the other one is operating, and then update the second CPU when the upgraded CPU is returned to operating mode. This capability is useful for the life of the equipment, from the design, through manufacturing, to start-up and operation. Entellisis makes it easy to keep the equipment up to date with ever-changing needs.

It is very common to specify “fully equipped future breaker” cubicles when ordering a substation or line-up. The fully equipped future breaker cubicle contains line and load side primary disconnects, drawout rails, and a cutout in the cubicle door. Current sensors are located in the compartment and a Messenger is placed above the breaker compartment. Adding a new feeder can then be as simple as removing a cover from the cubicle door and installing the breaker as well as inputting

the circuit breaker protection settings and data into the CPUs via the HMI.

Standard bus configurations used in Entellisis have provisions for future bus extension built in. Should the switchgear have no future breaker compartments, additional vertical sections can be mechanically and electrically connected to the Entellisis line-up without modifications or the use of transition sections.

Conclusion

These are the building blocks of an Entellisis low-voltage switchgear lineup. The Entellisis architecture enables new, powerful protection, monitoring, and control capability in a flexible system that can be updated over the lifetime of the equipment. These capabilities and application improvements are discussed in more detail in the following sections.

Notes

Entellisys Low-Voltage Switchgear

Section 4. Minimizing Potential Exposure to Arc Flash Energy

This section addresses the ownership and operation of Entellisys low-voltage switchgear for maximum reliability and minimal arc flash risk.

Low-voltage switchgear can be expected to have a long life within the facility's electrical power distribution system. It can reasonably be expected that, during that time, the equipment will need to be operated and maintained, even modified and expanded. Entellisys provides significant advantages over more traditional technology for owning, operating, and maintaining the equipment. This section describes some of Entellisys's inherent capabilities and how to use them to improve the ownership experience. The specific capabilities include:

- Complete control, monitoring, and setting capability from a remote location, reducing the need to have personnel near live electrical equipment.
- Remote racking device to allow racking in or out of circuit breakers by operators well outside the flash protection boundary¹. Operator safety is increased by eliminating the need to stand near the gear while racking circuit breakers into or out from a live bus.
- Fully selective fast protection to lower arc-flash energy in case of an arcing fault within the equipment. The protection is fast enough to lower PPE requirements and decrease the arc flash protection boundary while maintaining complete system selectivity.
- A family of fused circuit breakers provide current-limiting fuse performance across all circuit breaker frame sizes. Full current-limiting performance for all circuit breaker sizes provides optimum protection at high-fault values.
- Fully insulated and isolated bus to minimize potential bus faults. Minimizing live conductive surfaces reduces the probability of internal equipment faults due to contamination or mechanical damage.
- Fully compartmentalized circuit breakers to minimize arc fault transmission within the equipment. Grounded separation panels between circuit breakers and barriers between the front breaker cubicles and the rear bus and cable compartments minimizes the probability of transmission of an arcing fault from one equipment area to another.

- Circuit breakers use monitoring to drive need/use-based maintenance scheduling versus periodic time-based maintenance.
- Self diagnostic features provide notification that a device needs to be evaluated or changed.
- Flexible system design easily accommodates added or changed functionality. Entellisys makes it easy to modify installed equipment as the load requirements change.

Below are general descriptions of how Entellisys low-voltage switchgear provides more efficient and safer operation and maintenance of your electrical equipment. The specifics of some of the capabilities are covered in other sections of this publication.

Remote Control, Monitoring, and Metering

The Entellisys system architecture is specifically designed to work with all protection, metering, setting, and control functions performed with one of two redundant central computers. We refer to these computers as the CPUs. The system is accessed by an operator via software that may be resident on a specific Entellisys touchscreen (HMI or Human Machine Interface) or resident on a computer connected to a local- or wide-area network.

The Entellisys touchscreen (HMI) may be mounted directly on the equipment, in a freestanding equipment stack, or on a desk or wall. The flat-panel display may be located up to 300 cable feet away from the equipment.

All control and protection settings (other than long-time pickup) are made via the HMI software. All metering, status monitoring, event monitoring, and even waveform data can be viewed through the HMI. Furthermore, to confirm that the circuit breaker being viewed in the HMI screen is the same one being checked in the physical equipment, the Entellisys Messenger includes a blue LED light that can be switched on from the HMI software to verify circuit breaker location.

There are several benefits from this method of interfacing with the equipment versus the traditional method of looking at individual meters, circuit

¹ Flash protection boundary as defined in Article 130 of NFPA 70E, "Standard for Electrical Safety in the Workplace." The distance at which the incident energy equals 5 J/cm² (1.2cal. cm²) for situations where clearing time is longer than 0.1 seconds or 6.24 J/cm² (1.5cal/ cm²) where fault clearing time is 0.1 seconds or faster.

breaker trip units, and operating switches on the front of the gear or buttons on the front of the circuit breakers.

- The use of a large screen allows the operator to see multiple items simultaneously and to shift from one circuit to another or viewing system-wide information simultaneously.
- Perhaps more important, a remote HMI screen, whether on a computer or the Entellisys flat-panel display, allows operators to be far enough away from the gear that they need not expose themselves to the risks associated with operating live electrical equipment. Specifically, the operator can be located outside the flash-protection zone defined in NFPA 70E and need not wear cumbersome PPE to perform such duties as circuit breaker switching, throwover control, or other routine operational activities.

For further details on how the HMI software functions see Section 13.

Remote Racking

The electrically operated racking device allows maintenance personnel the ability to be up to 30 feet away from a draw-out circuit breaker during the racking operation, as shown in Figure 4.1. The electric motor is operated using convenient 115v AC power with a plug-in power cord. The gearbox is easily attached to the front of the breaker with a sliding latch connection. Allowing the user to be physically removed from the circuit breaker racking mechanics during operation provides peace of mind not normally available in a low-voltage application.

Figure 4.1
Remote Racking Operation



Furthermore, a circuit breaker may be opened via a remote HMI, so an operator can open a circuit breaker before approaching it to attach the remote racking mechanism.

Fully Selective Fast Protection

Section 7 describes how Entellisys protective functions provide fast and selective protection. In addition to lowering equipment and conductor damage due to faults within your power distribution system, Entellisys’s fast-protection capability also reduces the potential magnitude of incident arc-flash energy, based on the calculation methods in IEEE 1584 and NFPA 70E.

The potential incident energy resulting from an arcing fault is a function of the available short-circuit current at the point where the fault occurs and the time that the arcing fault current persists. The arcing current is also a function of voltage and system impedance. The Entellisys protection algorithms excel in their ability to identify a fault current and trip the right circuit breaker quickly; first, because of the short time delays and, second, because of the zone-based protection implemented in Entellisys.

The effect of clearing time on potential incident energy may be calculated with IEEE 1584 formulas. Figure 4.2 demonstrates the relationship between clearing times and prospective bolted fault current on potential incident energy for a 480v, high-resistance grounded system. Incident energy values for a 480/277v solidly grounded system would be slightly lower. The values were calculated per IEEE

Figure 4.2
Calculated Incident Arc Flash Energy

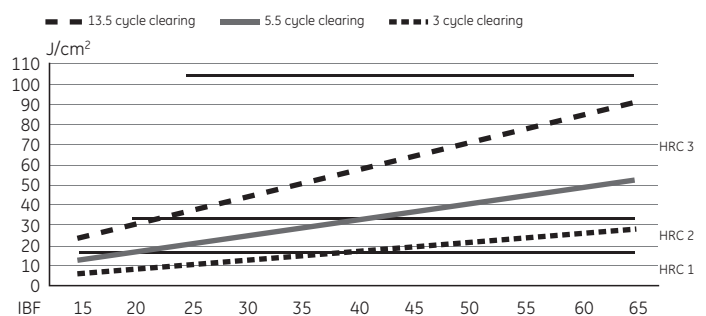

480 volt system, high resistance grounded, 18" working clearance, fault located within an IEEE 1584 defined 20 inch square enclosure. Lines drawn under following assumptions:
 • 480V, HRG, 18" working distance, enclosed fault
 • 3 cycle = instantaneous, 5.5 = 1st time band and 13.5 cycle = 2nd time band clearing time

1584-2002. The equations represent an 18-inch working distance, 32-millimeter gap (typical of low-voltage switchgear), and a 20-inch enclosure around the fault event to represent a typical circuit breaker cubicle.

Note that a total clearing time of 3 cycles keeps the HRC at level 2 or below for systems with prospective short-circuit currents of 65kA IC or less. Three cycles represent the maximum clearing time for the instantaneous function of any GE ANSI circuit breaker. The minimum time-delay band of an EntelliGuard circuit breaker clears in 5.5 cycles. Figure 4.2 demonstrates that this clearing time is able to keep the circuit’s HRC at level 2 for prospective bolted fault values up to 40kA and at HRC 3 for bolted fault values of 65kA IC and above. Entellisys’s second time-delay band clears in a maximum of 13.5 cycles. In 65kA systems, this clearing time will keep the HRC in the level 3 range.

Specific settings may affect the HRC level for the feeder’s zone of protection. An 800A or 1600A feeder without instantaneous protection should achieve a maximum HRC of 3 while maintaining complete selectivity. Judicious use of the instantaneous pickup should maintain the HRC at a maximum of level 2, with very good selectivity with downstream molded-case feeder breakers.

The Entellisys system is able to employ time delays as short as 0.025 seconds (25 milliseconds), the equivalent of 1.5 cycles pickup at 60 Hz. This fast time band is sufficient to clear the instantaneous band of any current-limiting or fast molded-case

circuit breaker used below an EntelliGuard feeder with an instantaneous clearing time of 1.5 cycles or less. Any EntelliGuard circuit breaker set at minimum time delay will clear at 0.092 seconds (5.5 cycles) or less for fault currents above the circuit breaker’s frame size, while maintaining complete selectivity with at least one layer of fast molded-case circuit breakers below. Figure 4.3 shows the time-current plots for a 225A Spectra circuit breaker that is selective with the 800A ANSI EntelliGuard circuit breaker above it.

To achieve better protection, it may be desirable to have an instantaneous setting on the switchgear ANSI circuit breaker that slightly limits the selectivity. Since the molded-case circuit breaker is probably located in remote equipment, the possible fault current at the circuit breaker may be significantly lower. Furthermore, the most probable location of a fault is at or near the load for that feeder circuit breaker, further increasing the impedance to the fault location and thus lowering the fault current. If the fault is arcing, the actual fault current may be still lower, allowing the molded-case circuit breaker to function within its instantaneous range, while being completely selective with the 800A feeder in the switchgear. A combination of minimum time-delay band and instantaneous settings for both 800A feeder circuit breakers allows the HRC level within their zone of protection to stay at level 2 or below for potential bolted faults up to 65kA. This scenario is similar with a 1600A EntelliGuard feeder. The time-current plot shown in Figure 4.4 demonstrates the potential curve relationship

Figure 4.3
800A Feeder Selectivity

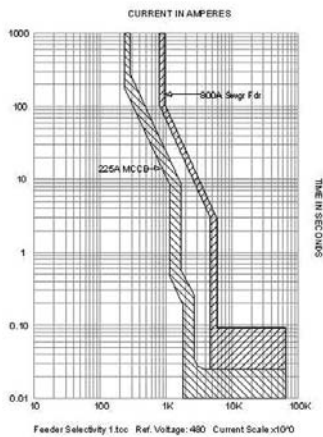

An Entellisys minimum time delay band will be selective with the instantaneous band of any Spectra circuit breaker shown with a clearing time band of 25 milliseconds or less.

Figure 4.4
1600A Feeder Select

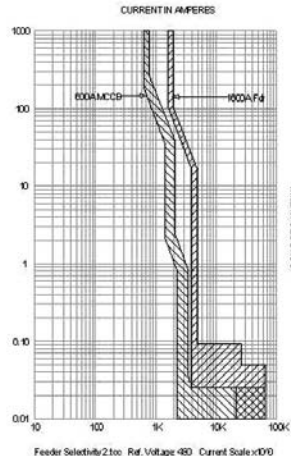

between a 1600A ANSI feeder and a 600A molded-case Spectra circuit breaker.

Main bus protection on a traditional system is always a challenge and forces the system design engineer to make some compromises. Traditional selectivity can only be achieved by sacrificing protection, since the main and tie circuit breakers must be set with enough time delay to clear the delay of the feeder circuit breakers fed from the bus. Often this requires the main to be set several time delays above its potential minimum. Faster time delays allow some improvement in protection. For Entellisys time delays in a typical double-ended substation feeder, the tie and a main may be selective with the feeder set a minimum time delay of 0.025s, the tie at 0.100s, and the main at 0.217s. The incident arc flash energy that may be let through by devices at these settings is shown in Figure 4.5 The main circuit breaker is able to keep the bus at an HRC level 4 for about 60kA IBF or less.

However, the Entellisys system can provide better protection with its zone-based protection function. As described in Section 7, Entellisys employs a bus-differential algorithm with zone interlocking to provide zone-based overcurrent protection for a wide range of fault values. This overcurrent protection can be set from below the bus’s full current rating up to the full short-circuit capability of the individual circuit breakers. When set in this manner, the tie and main circuit breakers can be operated at minimum time delay for a wide range of fault values, while

providing complete selectivity with the feeder circuit breakers. The IEEE 1584-calculated arc flash incident energy for a 480v high-resistance grounded system within a low-voltage switchgear cubicle operating at the minimum time delay of 25 ms is able to remain at HRC 3 or below with up to 100kA IC available at 480 volts. Delay-based coordination requires that the main circuit breaker be set at one of the longer delays, while the zone-based protection for the same bus can be set at minimum delay for all fault magnitudes, 100% selectivity. With a longer delay, the calculated arc flash energy for a 65kA system is above HRC 4, while it is only slightly over HRC level 2 with the minimum time delay.

Because the bus-differential algorithm may be set as low as 20% of the largest CT on the bus, 4000A bus-differential protection may be set as low as 800A. The zone-interlocking algorithm functions as high as the full short-circuit rating of the circuit breaker. This allows the circuit breaker to operate at the same speed regardless of fault magnitude, while remaining completely selective.

Potential incident arc-flash energy can be further reduced by employing the instantaneous trip of the main and tie circuit breakers or fuses at the feeder level. EntelliGuard circuit breakers are available with series current-limiting fuses. Class L fuses rated at 2000A and below are useful for limiting arc flash energy in 480v systems. Class L fuses in feeder circuit breakers, rated above the circuit breaker’s long-time trip setting but no larger than 2000A, can

Figure 4.5
Arc Flash Energy, Main Bus and Feeder with Selective Delays

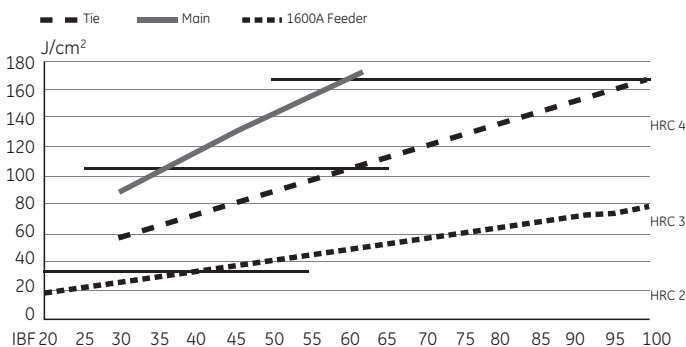

In this example the main CB clears in .317 seconds, the tie in .2 seconds, feeder in 0.092 seconds. These represent faster delays than often are used. With a tie and main circuit breaker set to be selective with each other and a typical feeder HRC may be kept below level for for systems with up to 55-60kA available. Based on a 480V, HRG switchgear system, 18" working distance.

Figure 4.6
Arc Flash Energy, Main Bus, Feeder and Branch

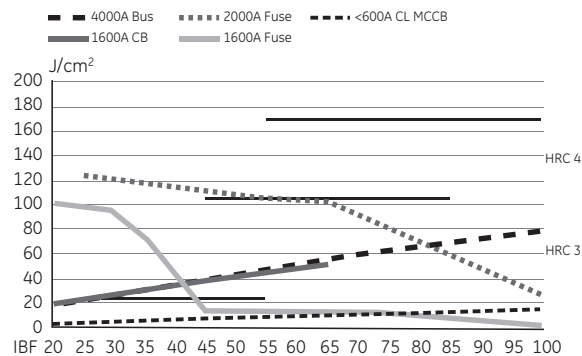

480V, HRG, 32mm gap, 18" working clearance. Spectra CB, 600A or less, instantaneous set as high as maximum. 1 cycle clearing time. Above CL threshold CB should be faster and limit IE significantly more.

provide significant reduction in incident energy for the highest potential short-circuit current, while providing fair selectivity with smaller circuit breakers below.

The incident arc-flash energy plot in Figure 4.6 shows a bus with a 4000A main and tie both operated by a zone-based protection algorithm set to pick up at 4000A with minimum time delay, a 1600A feeder set at minimum time delay, a 2000A fuse and a 400A molded-case circuit breaker. The incident-energy plot provides an indication of the calculated incident arc-flash energy for the main bus and feeder circuit. The incident-energy plot also shows a 1600A fuse that could be used with an 800A switchgear feeder. The incident energy plot for a GE current-limiting Spectra circuit breaker is similar for all circuit breakers rated 600A and below for prospective short-circuit currents of 20kA and above.

In summary, Entellisys can provide fast protection for the main bus, limiting maximum HRC to level 3 for systems rated up to 100kA IC at 480v. Feeder circuits can also be kept at HRC 3 or better with complete selectivity with downstream molded-case circuit breakers at fault currents up to 65kA. In combination with an instantaneous trip or fuses, it may be possible to achieve reasonably good selectivity with downstream branch protectors while keeping feeder circuit HRC to level 2 or lower for systems rated up to 100kA IC at 480v.

Circuit Breaker and Compartment Considerations

Closed-door Operation

Circuit breaker compartment doors have no ventilation openings, thus protecting operators from hot ionized gases vented by the breaker during circuit interruption.

Wheels and Guidebar

All EntelliGuard circuit breakers are equipped with wheels and a guidebar to provide easy and accurate drawout operation. When installing the breakers, they are lowered onto the extended drawout rails. Wheels on the side of the breaker allow the breaker to be easily rolled into the cubicle until the breaker engages the racking pins in the cubicle. The breaker is equipped with a rugged guidebar that ensures precise alignment of the primary and secondary disconnects during insertion and withdrawal.

Closed-door Drawout

True closed-door drawout construction is standard

with all Entellisys equipment. The breaker compartment doors remain stationary and closed while the breaker is racked out from the CONNECT position, through TEST, to the DISCONNECT position. Doors are secured with rugged 1/4-turn latches.

Racking Tool

If a remote racking device is not used, a racking tool may be used. This is a special drive wrench with a square 1/2" socket that engages the racking mechanism on the breaker. One racking tool is used for all EntelliGuard circuit breakers.

Low-Voltage Power Circuit Breaker Locking

As a standard feature, the EntelliGuard low-voltage power circuit breaker can be padlocked in the open position with up to three 1/4" - 3/8" shank padlocks to prevent unauthorized closing.

Breaker Insertion and Withdrawal Interlocks

Interlocks prevent racking the breaker in or out when the breaker contacts are closed. Circuit breakers are trip free when not in the CONNECT or TEST position.

Defeatable Door Interlock

This option prevents inadvertent opening of the compartment door unless the breaker is in the TEST or DISCONNECT position. A provision is made for authorized defeat of the interlock.

Padlockable Door Latch

This optional feature enables padlocking of the door latch in order to prevent unauthorized entry into the breaker compartment.

Drawout Padlock Provision

EntelliGuard and Entellisys offer an array of standard, safety locking features that provide extra measures of security when breaker, equipment, or load maintenance is performed. In addition to the padlocking feature on the breaker that keeps it open and trip-free, EntelliGuard breakers are also equipped with provisions to padlock them in either the TEST or DISCONNECT position. Furthermore, breaker cubicles are furnished with padlocking provisions on the drawout rails to prevent unauthorized installation of a breaker that has been removed from the cubicle for equipment or load maintenance.

This array of locking features should accommodate any type of "lockout - tagout" procedure a user may have implemented at their facility. All of the

padlock provisions on EntelliGuard breakers and Entellisys equipment will accept any combination of up to three padlocks with 1/4" to 3/8" diameter shank.

Key Interlocks

This option allows locking of the circuit breaker in the open, trip-free position when fully connected. Applicable schemes would be mechanical interlocking of two breakers so only one can be closed at a time or, in load center unit substations, interlocking of the primary switch and secondary main breaker such that the secondary main must be open before the primary switch can be operated. Single and double key locks are available. Key locking does not prevent operation when the breaker is in the TEST or DISCONNECT position.

Network Interlock

The network interlock is a mechanical lockout device optionally mounted on electrically operated circuit breakers. This is a logic driven interlock and is described in more detail in Section 5.

Breaker Position Switch

A breaker position switch is optionally available for use in breaker control schemes. When supplied, the position switch will provide indication of the breaker drawout position on the HMI breaker status screen. Descriptions of interlocking in automatic throwover schemes is discussed in more detail in Section 11.

Isolated Breaker Compartment

Each circuit breaker is located in a completely enclosed ventilated compartment with grounded steel barriers to minimize the possibility of fault communication between compartments.

Circuit Breaker Rejection Feature

A rejection system is provided as standard in each breaker compartment to prevent the insertion of a breaker with inadequate short circuit and/or incorrect continuous current ratings. EntelliGuard circuit breakers of a larger frame rating may be placed in a smaller frame rated compartment, provided they have similar dimensions. For example, a 2000A frame may be placed in an 800A frame compartment and a 4000A circuit breaker may be placed in a 3200A compartment. Consequently it is possible to reduce the number of spare circuit breakers required to have on hand.

Safety Shutters

Safety shutters protect operators from accidental contact with live conductors when the breaker is withdrawn. They are provided as a standard feature on main and tie breakers in multi-source substations and are optionally available in all other breaker compartments.

Equipment Considerations

Fully Tin-Plated Copper Bus

A fully tin-plated copper main and riser bus is a standard feature on Entellisys equipment. Tin plating provides superior corrosion protection, especially for application in the pulp and paper and waste treatment industries where corrosive agents routinely exist. GE's bus bars are tin-plated after forming and punching to ensure completely plated bolt holes and bar edges. Sliding contact surfaces, such as breaker stab tips, are fully silver-plated. Fully silver-plated bus is available as an option.

Bus System

Bare bus is provided as standard on Entellisys switchgear. In this configuration, there are no covers to remove, so all bus connections are easily accessible for maintenance. Note that a horizontal isolation barrier is provided between the vertical buses at every main and tie breaker for added safety in the event of a fault. An insulated/isolated bus system that fully insulates the horizontal main bus with a fluidized epoxy coating and isolates each phase of the vertical riser bus is optionally available. Accessibility to main bus joints is provided by replaceable covers, and no live connections are reachable from the rear except the breaker load side terminals. Bus compartmentation is also available as an optional feature on Entellisys switchgear. Vertical and horizontal buses are isolated from the cable compartment by glass reinforced polyester barriers.

Infrared Scanning Windows

Two types of infrared (IR) scanning windows are optionally available in Entellisys for ease of thermal scanning the power cables and terminations. In bare bus construction it is also possible to scan bus joints. One type of window is an aluminum mesh in an anodized aluminum housing with an aluminum security cover. Also available is an IR crystal that is transparent in the visible spectrum and it, too, has an aluminum security cover.

Entellisys Low-Voltage Switchgear

Section 5. EntelliGuard Breaker

The EntelliGuard circuit breaker is similar in construction to the GE WavePro metal frame low-voltage power circuit breaker, except the EntelliGuard breaker has no trip unit or current sensors. EntelliGuard breakers are ANSI-tested, UL Listed, and designed to withstand short circuit stresses equal to their short time interrupting ratings. This allows maximum selectivity with downstream devices when short time tripping characteristics are used. They include a closed-door drawout mechanism that is used to move the breaker from the DISCONNECT to the CONNECT position. The drawout mechanism can be operated manually at the front of the cubicle, or a remote racking device can be attached to the breaker for electrically racking the breaker through its drawout positions. Remote racking can be operated from up to 30 feet from the front of the switchgear line-up, providing an extra measure of safety between the operator and the energized equipment.

EntelliGuard breakers can be supplied in one of two forms – manually operated or electrically operated. Manually operated breakers are provided with a flush-mounted manual spring charging handle and mechanical CLOSE and OPEN buttons on the front of the breaker escutcheon. Electrically operated breakers are supplied with the same manual charging mechanism and mechanical CLOSE / OPEN buttons, but are also equipped with a 120v AC spring charging motor, close coil with anti-pump circuit, and shunt trip coil. The manual charging handle and the OPEN / CLOSE push buttons are double insulated from live components to provide additional operator

safety. Entellisys can close, open, and trip an electrically operated breaker. Manually operated breakers can only be tripped by Entellisys.

All EntelliGuard breakers have front-mounted indicators for breaker drawout position (CONNECT / TEST / DISCONNECT) and closing spring status (CHARGED / DISCHARGED). Standard padlock provisions, for up to 3 padlocks, are supplied on all breakers as a means to prevent unauthorized or accidental breaker closing during maintenance operations.

Accessories

Accessories for the EntelliGuard breaker are limited to a bell alarm with lockout and network interlock. All other functions for breaker control and monitoring are part of Entellisys and are enabled via software.

The bell alarm with lockout operates whenever an overcurrent protective function trips the circuit breaker. This device will mechanically lock out the circuit breaker and is reset manually via a reset button on the front of the breaker escutcheon. The bell alarm can also be programmed to operate and lockout the circuit breaker for any or all of the protective relay options provided by Entellisys.

The network interlock is also a mechanical lockout device mounted on the circuit breaker. It is a logic-driven interlock and has two states – SET (LOCKOUT) and RESET. Setting the Network Interlock to LOCKOUT when the breaker is closed will cause the breaker to trip. In the LOCKOUT position, the Network

Figure 5.1
EntelliGuard Breaker

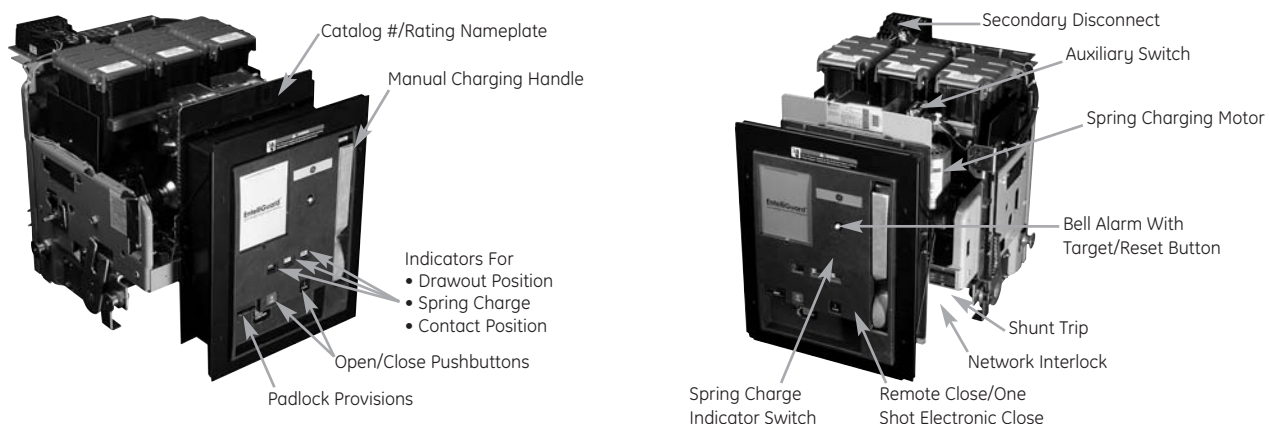

Interlock holds the breaker mechanically trip free and also inhibits electrical closing. The control logic in Entellisys must provide a command to reset the Network Interlock before the breaker can be closed manually or by control logic. Loss of control power will not cause the Network Interlock to reset.

Discussions of other components associated with the EntelliGuard breaker and cubicle follow.

Auxiliary Switch

The auxiliary switch contacts are used for indication of the breaker main contact position. An auxiliary switch is provided on all manually and electrically operated breakers. Auxiliary contacts are connected to the Messenger and provide breaker status input to the CPUs and to the Breaker Status screen on the HMI. The same auxiliary contacts also control the red and green LEDs on the front panel of the Messenger.

Fans and Fan Controller

The EG-50 (5000 amp) breaker is provided with integrally mounted cooling fans. Fan operation is controlled by the Messenger, which turns the fans on and off when the load current exceeds or drops below 4200 amperes. The switchgear control power transformer provides 120v AC control power for the fans. Power requirement for each fan is 0.2amps @ 120v AC (two fans installed).

Fuse Roll-out or Fuse Carriage

A fuse roll-out is used in conjunction with EntelliGuard breakers that are not integrally fused and are applied in high available short circuit current systems. The fuse roll-out is equipped with wiring and a secondary disconnect for blown fuse sensing. The sensing wiring is connected to the breaker-mounted Open Fuse Lockout (OFLO). The OFLO trips the circuit breaker whenever a fuse in the roll-out opens due to short circuit current interruption. EntelliGuard breakers type EGF-20, 32, 40 and 50 are supplied with the open fuse lockout. Key interlocking is required for both the circuit breaker and fuse roll-out to prevent removal or insertion of the fuse roll-out unless the circuit breaker is open.

Hidden Close Button

The Hidden Close button is provided on electrically operated EntelliGuard breakers when equipped with a Network Interlock. The Hidden Close button replaces the standard manual close button in the breaker escutcheon but provides limited access to

the mechanical close mechanism for emergency or supervised operation. A 0.100" diameter rod can be inserted through a hole in the Hidden Close button to manually close the breaker provided the Network Interlock is in the RESET position. The Hidden Close feature provides double insulation between the operator and any live parts in the breaker. The combination Hidden Close Button and Network Interlock is used on circuit breakers that traditionally would be electrically interlocked with other circuit breakers, such as in automatic transfer schemes.

Key Interlocks

Optional provisions for a key interlock are located on the left side of the breaker cubicle. Key interlocks are used to supervise the closing of a circuit breaker or the operation of upstream or downstream devices. Typical applications include interlocking main and tie circuit breakers to prevent paralleling and interlocking secondary main breakers with primary air switches. Breakers can be locked in the open position only. Normally, the key is removable when the lock bolt is extended, holding the breaker in a trip-free condition. Certain key interlock applications require the key to be removable when the breaker can be closed or when the lock bolt is withdrawn. Up to two key positions can be accommodated in each breaker cubicle.

Open Fuse Lockout (OFLO)

The open fuse lockout device is provided with any fused (EGF) EntelliGuard circuit breaker. The OFLO consists of an individual trip solenoid and target indicator for each circuit breaker pole, connected directly across the fuse in that phase. When any fuse blows, the solenoid is energized and trips the circuit breaker to prevent single-phasing. The EntelliGuard breaker is mechanically locked out and cannot be reclosed until the fuse is replaced and the target indicator on the OFLO is reset.

When the current limiting fuses are mounted in a separate fuse roll-out, as with EGF-20, EGF-32, EGF-40, and EGF-50 circuit breakers, the open fuse lockout is wired to the fuses through secondary disconnects on the fuse roll-out and on the circuit breaker.

Position Switch (By-Pass Switch or TOC Truck-Operated-Contact)

This optional accessory is mounted in the EntelliGuard breaker cubicle and is supplied with one

normally open and one normally closed contact. The position switch is used to indicate the drawout position of the breaker, and the switch contacts change state when the breaker is moved between the CONNECT and the TEST positions. The two contacts on the position switch are wired to the Messenger in the breaker cubicle and provide breaker drawout position indication on the Breaker Status screen at the HMI. They can also be used in any Flex Logic control scheme.

Spring Charge Indicator Switch

The spring charge indicator switch is provided on all electrically operated EntelliGuard circuit breakers and is wired to the Messenger. This contact provides status of the circuit breaker closing springs on the Breaker Status screen at the HMI and can also be used in Flex Logic control schemes.

Remote Close Accessory with One-Shot Electronic Close Circuit

The remote close accessory is an electrically operated solenoid which, when energized through the HMI or a Flex Logic control scheme, closes the EntelliGuard circuit breaker. The remote close accessory consists of the “one-shot” electronic close circuit, with built-in anti-pump feature, and the closing solenoid. The remote close accessory is continuously rated and operates as follows.

Applying control voltage to the close circuit through the Messenger produces a 250ms pulse to the closing coil which, in turn, releases the energy stored in the closing springs. The anti-pump feature prevents the breaker from repeatedly closing if the close signal is maintained. The Messenger provides a momentary close signal (1/2 second duration) whenever the HMI or Flex Logic issues a close command. Reset time for the anti-pump circuit is approximately 2.5 seconds.

Secondary Disconnect

All EntelliGuard breakers are furnished in drawout construction. The interface between the breaker and the Entellisys system occurs through a rugged, 36-point secondary disconnect mounted on the top of the circuit breaker. The secondary disconnect is engaged when the breaker is in the CONNECT and TEST positions and is disengaged when the breaker is in the DISCONNECT position. A feedback mechanism is provided on the secondary disconnect to confirm to Entellisys that the secondary disconnect

is properly engaged. Status of the secondary disconnect (Connected or Disconnected) is shown on the Breaker Status screen at the HMI.

Shunt Trip

The shunt trip allows remote electrical opening of the EntelliGuard circuit breaker through the HMI and Flex Logic. The shunt trip is supplied on all electrically operated breakers and is not available on manually operated breakers. The shunt trip coil is rated for intermittent duty and is supplied with an auxiliary switch contact that automatically removes control power from the coil when the breaker opens.

Spring Charging Motor

The spring charging motor is supplied on all electrically operated EntelliGuard circuit breakers. The breaker closing springs are charged automatically when control voltage is applied to the breaker. This typically occurs when the breaker is racked in to the cubicle and the secondary disconnect engages. When the breaker closing springs are fully charged, a cutoff switch de-energizes the charging motor. The closing springs will recharge automatically after a breaker closing operation. If control power is lost during the spring charging cycle, spring charging can be completed using the integral manual pump handle.

Ratings

The EntelliGuard breaker is available in 800, 1600, 2000, 3200, 4000, and 5000 amp frame sizes with short circuit interrupting ratings from 30kA to 200kA. The model number of the breaker indicates its interrupting capacity (IC). EGS indicates “Standard IC,” EGH indicates “High IC,” EGX indicates “Extended IC,” and EGF indicates “Fused.”

High IC and Extended IC breakers are used with larger kVA substation transformers as well as in paralleling applications. Fused circuit breakers have a 200kA IC rating for use in large network systems.

Table 5.1 lists the interrupting capacities (IC) for EntelliGuard breakers at system operating voltages.

Catalog Numbers

A unique catalog number identifies all EntelliGuard breakers. The catalog number contains information on the breaker frame rating (continuous current and short circuit), the fuse rating (if equipped with

current limiting fuses), operation (manual or electrical), and accessories. Figure 5.2 provides the development of EntelliGuard breaker catalog numbers.

Wiring Diagram

Figure 5.3 shows the wiring for all standard EntelliGuard circuit breakers. All breakers include an auxiliary switch and flux shift trip coil.

Electrically operated breakers include spring charging motor, close coil with anti-pump circuit, shunt trip, and remote charge indicator switch. Cooling fans are supplied only on 5000A EntelliGuard breakers. Bell alarm with lockout is an option for both manually and electrically operate breakers. Network interlock is an option for electrically operated breakers only.

Table 5.1
EntelliGuard LVPCB Interrupting Capacity

EGS Standard Interrupting EGH High Interrupting
EGX Extended Interrupting EGF Fused⁽¹⁾ (200kA IC, 600v max)

Rated AC Voltage, Nominal (max)	Breaker Type	Frame Size (amps)	Short Circuit Interrupting Capacity, RMS Symmetrical kA			
			Short-Time Withstand	With Instantaneous Trip	Without Instantaneous Trip	
600 (635)	EGS-08	800	30	30	30	
	EGH-08		42	42	42	
	EGX-08		50	50	50	
	EGS-16	1600	42	42	42	
	EGH-16		65	65	65	
	EGS-20	2000	65	65	65	
	EGS-32	3200	65	65	65	
	EGH-32		85	85	85	
	EGX-32		85	85	85	
	EGS-40	4000	85	85	85	
	EGX-40		85	85	85	
	EGS-50	5000	85	85	85	
EGX-50	85		85	85		
480 (508)	EGS-08	800	30	30	30	
	EGH-08		42	42	42	
	EGX-08		65	65	65	
	EGS-16	1600	50	50	50	
	EGH-16		65	65	65	
	EGS-20	2000	65	65	65	
	EGS-32	3200	65	65	65	
	EGH-32		85	85	85	
	EGX-32		100	100	100	
	EGS-40	4000	85	85	85	
	EGX-40		100	100	100	
	EGS-50	5000	85	85	85	
	EGX-50		a	100	100	
	240 (254)	EGS-08	800	30	42	30
		EGH-08		42	50	42
EGX-08		65		65	65	
EGS-16		1600	50	65	50	
EGH-16			65	65	65	
EGS-20		2000	65	65	65	
EGS-32		3200	65	85	65	
EGH-32			85	130	85	
EGX-32			100	130	100	
EGS-40		4000	85	130	85	
EGX-40			100	130	100	
EGS-50		5000	85	130	85	
EGX-50	100		130	100		
600 (600)	EGF-xx	ALL		200	200	

⁽¹⁾ 800 & 1600A frame breakers are integrally fused. Larger frame breakers (2000 - 5000A) require a separate fuse roll-out for 200kA IC rating.

Figure 5.2
EntelliGuard Low-Voltage Power Circuit Breaker Catalog Numbers

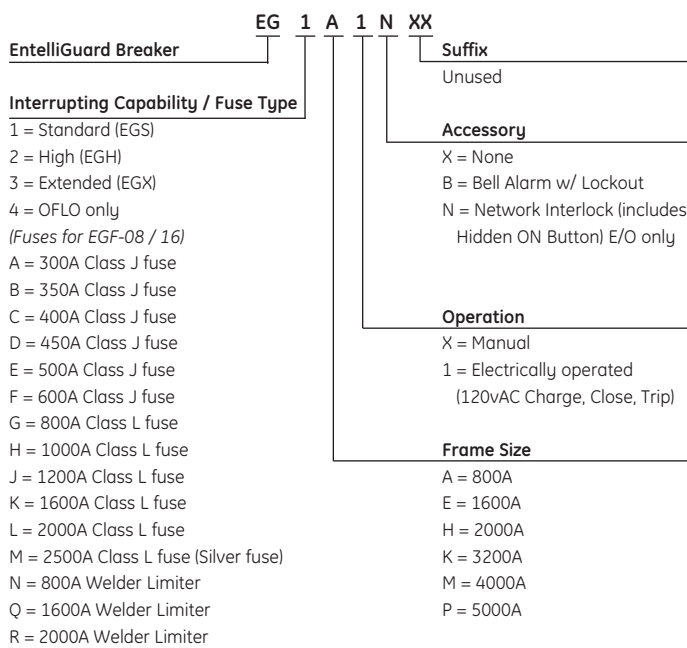

Refer to Table 5.2 for allowable fuse, sensor, and trip ratings for EGF-08 / 16 breakers

Figure 5.3
Wiring Diagram

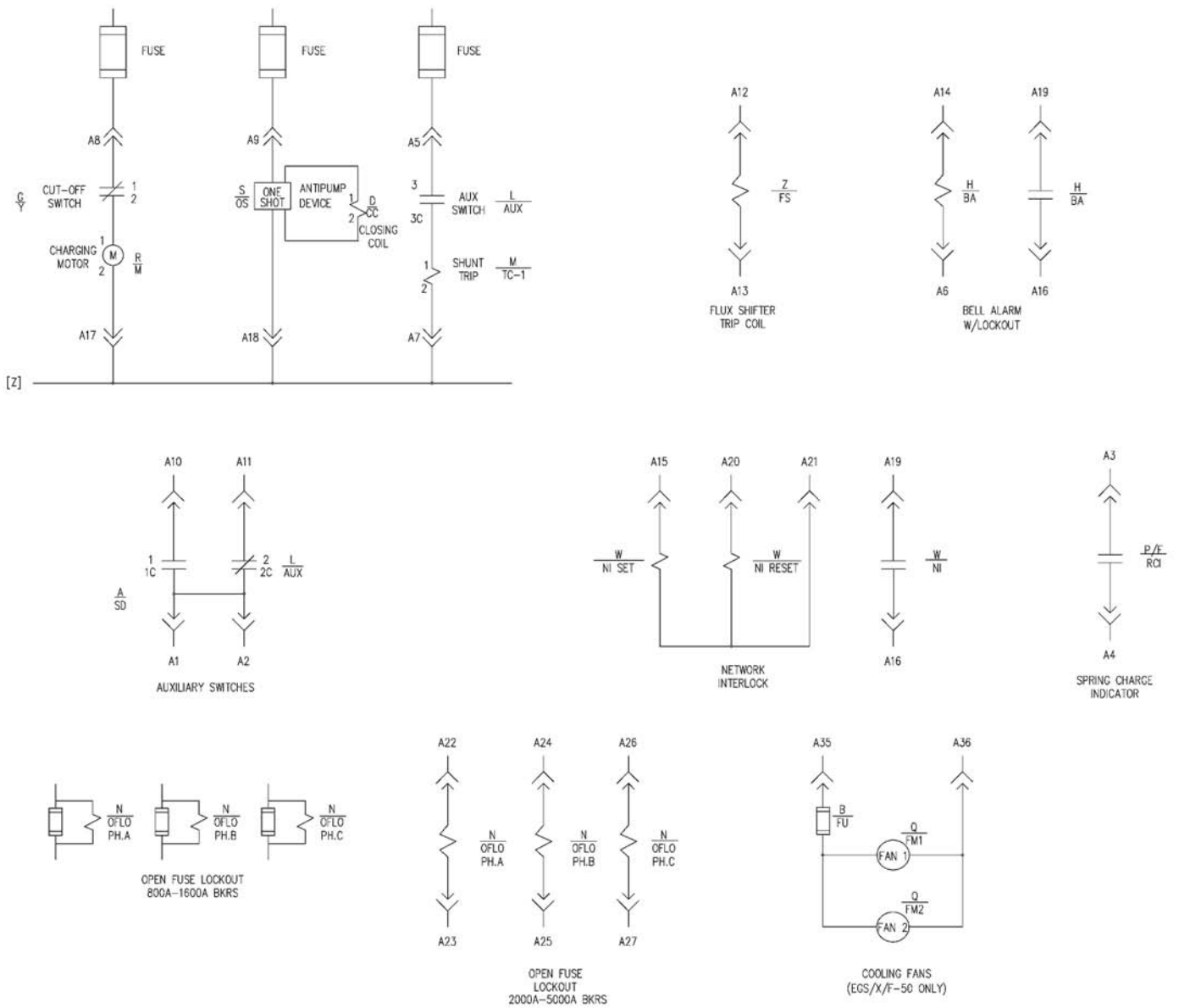

Table 5.2
Allowable Current Limiting Fuse Sizes for EntelliGuard Breakers

Breaker Type	Frame Size	Sensor Rating	Messenger Current Setting Switch	Ferraz-Shawmut Fuse Range ⁽¹⁾			
EGF-08	800A		Below 150A	300/350/400/450/500/600/ 800*/1000*/1200*/1600*A			
			150A				
			225A				
						300A	400/450/500/600/800*/1000*/ 1200/1600*A
					400A		
					600A		
					700A		
		800A	800A	800*/1000*/1200/1600*A			
			800A	1000*/1200/1600*A			
EGF-16	1600A		400A and below	450/500/600/800*/1000*/1200/ 1600*/2000*/2500A ⁽³⁾			
				500A	500/600/800*/1000*/1200/ 1600*/2000*/2500A ⁽³⁾		
				600A	600/800*/1000*/1200/1600*/ 2000*/2500A ⁽³⁾		
				700A	800*/1000*/1200/1600*/ 2000*/2500A ⁽³⁾		
				800A			
				1000A	1000*/1200/1600*/2000*/2500A ⁽³⁾		
				1200A	1600*/2000*/2500A ⁽³⁾		
				1600A	1600A	2500A ⁽³⁾	
EGS-20 ⁽²⁾	2000A	2000A	2000A and below	2000/2500A			
EGS-32 ⁽²⁾	3200A	3200A	3200A and below	2000/2500/3000/4000A			
EGS-40 ⁽²⁾	4000A	4000A	4000A and below	2000/2500/3000/4000/5000A			
EGS-50 ⁽²⁾	5000A	5000A	5000A and below				

* These fuse sizes are also available as Welder Limiters.

⁽¹⁾ Class L fuses less than 800A are not UL or CSA listed. Use Class J fuses for 600A and below. The maximum fuse rating is the largest fuse that tests show will result in proper performance of the breaker and fuse in combination under short-circuit conditions. Only Ferraz-Shawmut fuses should be used for proper coordination.

⁽²⁾ Fuses are mounted in a separate roll-out element (fuses shipped as "XS" material).

⁽³⁾ Integrally fused 1600A frame breakers (EGF-16) equipped with 2500A fuses can be furnished with rating plugs from 300 – 1600A. Breakers equipped with 2500A fuses cannot be modified to accept lower rated fuses. EGF-16 breakers equipped with 2000A and lower fuses cannot be upgraded to 2500A fuses. The maximum trip rating for an EGF-16 breaker is 1200A when furnished with other than 2500A fuses (see table for min/max fuse rating for each rating plug value). 2500A fuses preclude the use of shutters in the breaker cubicle.

Entellisys Low-Voltage Switchgear

Section 6. EntelliGuard Messenger

The EntelliGuard Messenger (see Figure 6.1) is located above each circuit breaker cubicle and provides the interface between the CPUs and the EntelliGuard circuit breaker. The Messenger provides analog-to-digital conversion of the current signals taken from the breaker cubicle-mounted current sensors and of the voltage signals taken from voltage transformers connected to the switchgear bus. Any close, open, trip, or lockout commands issued to the circuit breaker by the CPU are translated by the Messenger and result in signals to the appropriate coils on the circuit breaker. Feedback from the circuit breaker, confirming any operation, is sent back through the Messenger to the CPU.

An EntelliGuard Messenger is configured at the factory with the appropriate breaker frame rating, current sensor rating, and overcurrent trip characteristics for each circuit breaker cubicle in the switchgear line-up. The front panel of the Messenger has two rotary switches for setting the trip rating of the breaker installed in the associated cubicle. One switch selects the current setting of the cubicle based on the installed current sensors. This is similar to the selection of a rating plug for a traditional breaker trip unit. The other switch selects the long time (overload) pick-up setting for the circuit (50-110% of the current setting). Table 6.1 lists the available current sensor values and associated current settings.

The Messenger has the following user-interface, programming, and protection features.

Indicator LEDs

Front panel LEDs show the location and operating status of the circuit breaker and the health of the system electronics, and they aid in programming the system.

- *Locator LED.* Positioned at the left end of the LED array, the blue Locator LED is used for programming the system and breaker control functions. When preparing to set any of the breaker protective functions, the Locator LED is set to flash for either 10 or 30 seconds and provides visual verification, from the front of the switchgear, that the intended circuit is being correctly addressed. The Locator LED can also be used in the same manner prior to executing a breaker CLOSE, OPEN, or TRIP command from the HMI. Entellisys also provides preventative maintenance information for each circuit breaker based on the fault duty of the breaker. The Locator LED can be used to correctly identify a circuit breaker when using the preventative maintenance screens on the HMI.
- *Communication LED.* Two green LEDs (labeled Com 1 and Com 2) provide status indication of the two communication channels to each Messenger. An illuminated LED indicates the communication wiring between the Messenger and the CPU is intact and information is being transmitted and received.
- *Power LED.* Two redundant sources of 120v AC power each Messenger. The green Power LED indicates the Messenger is receiving proper 120v AC control power.
- *Breaker status LEDs.* Two LEDs indicate circuit breaker OPEN / CLOSE status. The green LED indicates the breaker is open. The red LED indicates the breaker is closed. The red LED also monitors the breaker shunt trip coil and its control power source.

Test Port

The Messenger is provided with a DB-type 25-pin connector, accessible from the front panel, for connection to the Entellisys portable test kit. Seven analog signals representing three-phase voltages and currents plus neutral current are injected

Figure 6.1
EntelliGuard Messenger



directly into a Messenger’s A/D converter via the Test Port connector. The test kit can change the waveform characteristics of the sinusoidal signals to test the different overcurrent and protective relay functions for each circuit breaker.

Sealable Cover

A hinged, clear Lexan cover is installed over the LEDs, switches, and Test Port. The cover includes provisions for wire seals so that the current setting and long time pick-up selections can be sealed to meet the requirements of NEC for restricted access to the trip setting adjustments.

Self-Powered Mode

The Messenger is normally powered from the switchgear redundant control power buses with dual UPS back-up. In this operating mode, the Messenger passes digital signals of the currents and voltages to the dual CPUs and, in turn, receives and executes instructions from the CPUs if the currents and/or voltages require a breaker operation.

The Messenger provides overcurrent protection for the circuit in the event all control power is lost (loss of both control power sources and both back-up UPSs) or both redundant communication networks or redundant CPUs become unavailable. The Messenger’s self-powered mode utilizes power from the cubicle-mounted current sensors to power its internal circuits. When running in self-powered mode, the overcurrent protection curves built in to the Messenger utilize the maximum pick-up and delay settings for each applicable overcurrent function (overload, short circuit, and ground fault). Using the maximum pick-up and delay settings insures the self-powered overcurrent characteristics in the Messenger will not interfere

with the programmed settings running in the CPUs.

Compared to traditional low voltage circuit protection, the self-powered mode is similar to having a back-up integral trip unit on a circuit breaker that is programmed with all overcurrent characteristics set at their maximum values.

i-Button

A factory-programmed memory device called the “i-Button” provides the unique protection characteristics for each breaker cubicle in the switchgear line-up. Characteristics include the breaker frame size, the installed current sensor rating, and the overcurrent characteristics for the circuit. The i-Button programming determines the upper and lower limits for the overcurrent protection settings and the type of ground fault protection (none, standard, or switchable).

The i-Button and holder are tethered to the breaker cubicle and communicate with the Messenger via a slot in the side of the Messenger. Now, the unique characteristics of a given circuit are captured in the i-Button, which becomes a part of the breaker cubicle and therefore a part of the connected load.

The i-Button – Messenger – EntelliGuard breaker concept of Entellisys simplifies the task of determining component interchangeability and the quantity and type of spare parts to have on hand. All EntelliGuard Messengers are identical; therefore, only one catalog number is required for spare parts stocking. All EntelliGuard breakers for a given frame size and function are identical, thus requiring fewer spare breakers for the range of loads in a plant. Component interchangeability and reduced spare parts is one of the recognizable benefits of the Entellisys concept.

Table 6.1
Current Sensor Values and Associated Current Settings

Current Sensor Rating (Amps)	Current Setting (Amps)	Current Sensor Rating (Amps)	Current Setting (Amps)	Current Sensor Rating (Amps)	Current Setting (Amps)	Current Sensor Rating (Amps)	Current Setting (Amps)			
150	80	800	300	2000	750	4000	1600			
	100		400		800		2000			
	125		450		1000		2500			
	150		500		1200		3000			
400	150		1600		600		3200	1500	5000	3200
	200				700			1600		3600
	225				800			2000		4000
	250				600			1200		3200
	300	800		1600	4000					
	400	1000		2000	5000					
		1100		2400						
		1200		2500						
	1600	3000								
		3200								

Entellisys Low-Voltage Switchgear

Section 7. Protection

Entellisys low-voltage switchgear offers a broad array of familiar and expanded protection capabilities. All modes of protection except high-resistance ground-fault detection are available from every CPU without additional hardware. If your Entellisys equipment does not have the type of protection enabled that your power distribution system needs now, it can probably be easily added.

The Entellisys centralized single-processor system provides backup protection at the individual circuit breaker level. It offers overcurrent protection using traditional inverse-time characteristics, plus single-point relay protection, such as under- and overvoltage protection. All of this protection is provided by two CPUs, each providing redundant back-up to the other at all times. In addition, more redundant overcurrent protection is provided at the individual circuit breaker level by the Messenger associated with each circuit.

However, the Entellisys system offers much more than these traditional protection modes. Its ability to simultaneously consider all the voltages, currents, and circuit breaker conditions within the system provides zone-based protection and optimization of protective settings for a variety of situations. This includes changes in the topology or number of sources available, changes in load demand, and even changes in factors external to the gear that are communicated via the Entellisys system's I/O capability.

The result is selective protection for a wide range of fault values by delivering fast circuit interruption when needed, while shutting down only those circuits that absolutely must be shut down.

Maximum system reliability, lower fault energy let-through, and lower arc flash energy can all be achieved simultaneously. Minimum let-through and minimum arc flash energy can be obtained via quick settings when needed most.

This section describes the protective capabilities provided by Entellisys. Further detail is provided by various referenced GE publications that describe specific functions in more detail. Setting up and defining the exact protective levels you need are described in the appropriate GE Entellisys instruction book.

Traditional Overcurrent Protection

Broad range of settings

Each circuit breaker cubicle contains a set of current transformers (CTs) that provide the current signals for all overcurrent, relay, and metering functions. The Entellisys system needs no additional CTs. For circuit breaker frames rated at 2000 amperes and above, the CTs are sized to the circuit breaker frame. Smaller frames may have one of several CTs as listed in Table 7.1. All protective settings for each circuit breaker depend on the CTs in the corresponding cubicle.

The long-time pickup for each circuit breaker is set at the Messenger communication node above each circuit breaker. The rest of the protective settings for each circuit reside in software at each of the redundant Entellisys system central processor units (CPUs). The settings may be adjusted via the human-machine interface (HMI) for the system. The exception to this is the instantaneous trip setting that is made at the HMI and communicated to the

Table 7.1
Current Sensors and Current Switch Settings Available for Each CB Frame

Frame Size	Sensors	Rating Switch Values in Amperes
800	150	80, 100, 125, 150
	400	150, 200, 225, 250, 300, 400
	800	300, 400, 450, 500, 600, 700, 800
1600	800	300, 400, 450, 500, 600, 700, 800
	1600	600, 800, 1000, 1100, 1200, 1600
2000	2000	750, 800, 1000, 1200, 1500, 1600, 2000
3200	3200	1200, 1600, 2000, 2400, 2500, 3000, 3200
4000	4000	1600, 2000, 2500, 3000, 3200, 3600, 4000
5000	5000	3200, 4000, 5000

Rating switch and CT rating is set at the Messenger.

Entellisys Messenger, where it is resident until the CPU communicates a different setting.

The following is a list of the single-breaker over-current protection functions available:

- Long-time pickup (set at Messenger)
 - Four long-time delay bands (set via HMI)
- Short-time (selectable and set at HMI)
 - I²T slope in or out (selectable at HMI)
 - Seven short-time delay bands (set via HMI)
- Ground fault (optional) (settable at HMI)
 - I²T slope in or out (selectable via HMI)
 - Seven ground-fault delay bands (set via HMI)
 - Available from factory with GFI, without GFI or with selectable GFI (not UL listed)
- Adjustable instantaneous (selectable and adjustable via HMI)
- Backup protective function for each CB (set at Messenger via long-time pickup setting)

The nominal setting values and available current transformers are listed in Tables 7.1-7.8.

Time-delay bands for short-time and ground-fault protection

The Entellisys system provides seven time-delay bands for both short-time and ground-fault functions. The minimum time-delay bands for both short-time and ground-fault protection allow the protection

algorithm to sense and initiate a trip as quickly as 1.5 cycles, corresponding to 25 ms for 60 Hz or 30 ms for 50 Hz systems. This allows circuit breakers to clear in less than six cycles, regardless of fault magnitude, while being selective with molded-case circuit breakers that may be connected downstream of the switchgear feeder. The time-delay bands for EntelliGuard circuit breakers are selective with any molded-case circuit breaker that is able to clear in one cycle or less.

Heating and cooling algorithm

The long-time, short-time, and ground-fault protection functions are provided with an algorithm that accounts for the heating and cooling effects of intermittent high currents. A counter is started when the long-time function is engaged. If the circuit current falls below the threshold, the long-time function is no longer in pickup and the counter starts decrementing. If the current level increases to again engage the long-time pickup, the counter resumes incrementing from its present count. This protects against the potentially harmful effects of cycling high loads that slowly build up heat in conductors.

Instantaneous setting

When provided, instantaneous protection resides at the Entellisys Messenger, but is set via the HMI.

Table 7.2
Long Time Pick Up

Set at .5 to 1.1 of rating switch value
Long Time Pick Up band centered at nominal current value ±10%

LTPU determined by setting switch and rating switch position. Both are located and set at the Messenger.

Table 7.4
Short Time Pick Up

Set at 1.5 to 9 of Long Time Pick Up value
Short Time Pick Up band centered at nominal current value ±10%

Short time pick up is set at the CPU via the HMI.

Table 7.3
Long Time Delay Bands

Long Time Delay Bands	Nominal Time at which Time Delay Bands Intersect the Long Time Pick Up Band
Band 1	108 seconds
Band 2	216 seconds
Band 3	432 seconds
Band 4	900 seconds

This time represents the nominal pick up time for the band and excludes circuit breaker clearing time. The trip-time band width in the time scale is +20% to account for circuit breaker clearing time and CT sensing accuracy. Refer to the time current curve.

Table 7.5
Short Time Delay Bands (Milliseconds)

Band	60 Hz		50 Hz	
	PU	Clear	PU	Clear
1	25	92	30	90
2	58	158	60	160
3	100	200	100	200
4	167	267	170	270
5	217	317	220	320
6	283	383	280	380
7	400	500	400	500

Where the I²T band is enabled, the slope of the band shall be an I²T =K slope. Where K = 18 and I = (C × I_{RMS}) = Rating Switch × Setting Switch × I_{RMS}. The I²T slope shall extend from the short time pick up band to the time delay band selected. Refer to the time current curve.

The adjustment range for instantaneous protection depends on the size of the circuit breaker and whether or not the circuit breaker is provided with the short-time function. Once set, instantaneous protection does not depend on the continuing operation of the CPU or the communication system. Table 7.6 lists the available instantaneous settings.

If the switchgear is started from a blackout condition with a circuit breaker closed, the Entelliguard circuit breaker with instantaneous trip has built-in backup instantaneous protection set at 1.7 times the maximum short-time setting of the circuit breaker. Until the CPU downloads a user-defined setting to the node, this fixed rating provides a safety backup. As soon as the CPU communicates a setting to the node, the new user-defined setting takes over.

Entelliguard circuit breakers have no making-current release or hidden instantaneous. Except for a black start condition as described in the preceding paragraph, the circuit breakers have sufficient close and latch ratings to be equally selective upon closing in on a fault as they do during normal power-on conditions.

Long-time, short-time and ground-fault settings

Each Entelliguard circuit breaker is provided with an adjustable long-time characteristic, an instantaneous

and a short time response. Each circuit breaker must be set with either short time, instantaneous, or both. Ground-fault detection or ground-fault tripping is a factory option. Ground-fault protection, if desired, must be programmed at the factory to maintain a UL listing for the equipment. User selectable ground fault protection is available, but that option is not UL listed.

Available settings for the various overcurrent protective functions are described in Tables 7.2-7.8.

Backup protection

Each Entellisys Messenger is provided with self-powered backup protection that protects the power circuit breaker if proper communication to the CPU is lost or if the CPU does not issue the required protection commands. Backup protection consists of long-time pickup that is set with an adjustment switch on the front of the node. Fixed nonadjustable long-time delays, short-time pickup and delay, and ground-fault pickup and delay are also provided. These are set at the maximum capability of the circuit breaker. If the circuit breaker is equipped with instantaneous protection, backup instantaneous tripping is also provided at 1.7 times the maximum short-time setting of the circuit breaker at any time that the circuit is operating without a user-defined instantaneous level set by the CPU. At all other times,

Table 7.6
Instantaneous Pick Up Settings

Circuit Breaker Frame Size	Maximum Instantaneous Setting	
	Short-Time Enabled	Short-Time Not Enabled
800	15	10
1600	15	10
2000	15	10
3200	13	10
4000	9	9
5000	7	7

Setting is a multiple of the Setting Switch Value. Minimum instantaneous setting is 1.5. Settable in increments of .5. Instantaneous is set via the HMI but it is resident at the Messenger and the instantaneous trip is calculated at the Messenger independent of activity at the CPU.

Table 7.7
Ground Fault Pick Up

Sensor	Pick up setting range
150-2000	0.2 - 0.60
3200	0.2 - 0.37
4000	0.2 - 0.30
5000	0.2 - 0.24

Pick up setting is times current sensor rating. Setting increments are 0.01.

Table 7.8
Ground Fault Delay Bands (Milliseconds)

Band	60 Hz		50 Hz	
	PU	Clear	PU	Clear
1	25	92	30	90
2	58	158	60	160
3	100	200	100	200
4	167	267	170	270
5	217	317	220	320
6	283	383	280	380
7	400	500	400	500

Where the I²T band is enabled, the slope of the band shall be an I²T =K slope. Where K = 2? and I = (GFPU x I_{GF RMS}) = Ground Fault Pick Up x CT rating x Ground fault current. The I²T slope shall extend from the short time pick up band to the time delay band selected. Refer to the time current curve.

the instantaneous setting is the user-defined level set at the HMI and acted upon by the circuitry in the Messenger. Backup protection is self-powered from the fault current and does not rely on control power, the CPUs, or the communication networks.

Topologies, Zones, Tiers, and Dynamic State Changes

The Entellisys system supports various protection functions by keeping track of which power sources are live and feeding each active bus. This allows the Entellisys CPU to optimize multiple types of protection for multiple bus and source configurations. The CPU can also associate power sources to voltage transformers, depending on which source circuit breakers are closed or open.

The Entellisys system can support up to four buses and zones in one substation with up to 30 total circuit breakers; eight of the devices may be defined as *topology circuit breakers*. A topology circuit breaker controls power to a bus and is usually a tie or main. The system can support up to 16 different topologies for a four-bus system. The maximum number of topologies is 2^B , where B is the number of buses. Identification of the maximum number of distinct topologies is usually not required, as several of the different topologies are handled similarly. Topology 0 is reserved for maintenance purposes and allows all settings to be user defined for main-

tenance procedures. These typically would be minimum settings to provide maximum protection.

A *zone* defines the circuit breakers controlling the power to a bus and the feeders and sub-feeders connected to the bus. A circuit breaker may be part of more than one zone; for instance, tie circuit breakers may belong to two zones. Zones do not change once they are defined. However, the number of closed-source circuit breakers that power a specific zone at any time may change. Each combination of open- or closed-source circuit breakers feeding a zone can be considered a different *topology*. A change from one topology to another is called a *state change*. Protection algorithms and assignments of potential transformers for voltage measurement may change when there is a state change. Zones are used for multi-source ground-fault protection and differential protection as well as zone interlocking. Topology definitions are used for the same functions as well as for potential transformer assignment and to trigger specific user-set protection settings.

Tiers are the hierarchical definitions of circuit breakers within a zone. The tier designation may be changed for each breaker in a zone based on the specific topology active at a particular time. Up to four tiers may be supported within each zone. Tiers are used with zone-selective interlocking (ZSI) for short-time and ground-fault protection. Tier assignment to a

Table 7.9
Ground Fault Options

GF Option Factory Enabled at Node	GF Switchable at Messenger	Trip or Alarm Selection at C/CPU	UL Listed as GF Device	Comments
Enabled	No	None - Must Be Trip	Yes	Node and C/CPU perform GF. C/CPU at user setting. Messenger at maximum
Disabled	Yes	Trip	No	C/CPU performs GF at user setting. Messenger performs GF only if user selected at C/CPU
Disabled	Yes	Alarm only	No	C/CPU performs GF at user setting. Messenger does perform GF.
Disabled	Yes	None	No	No GF at C/CPU or Messenger
Disabled	No	None	No	No GF at C/CPU or Messenger

particular circuit breaker may change because of a change from one topology to another (state change). For more information on how tiers function, see Section ?.

Topology and zone definitions are set at the GE factory when the switchgear is manufactured, based on the configuration of the equipment and the information about power sources to the equipment provided by the user. Tier definitions and other protective functions based on the zones and topologies are assigned by the user and may easily be changed at any time via the HMI. However, a GE factory engineer must make changes in zone and topology breaker definitions. Changes are only needed if new power sources are added or if the bus is reconfigured to change the number of source or tie circuit breakers. Additional loads should not require a change in factory settings.

A double-ended substation has eight different topologies possible:

- Both mains open, and tie open or closed 2
- One main or the other closed, tie open 2
- One main or the other closed, tie closed 2
- Both mains closed, tie open or closed 2
- Total 8

Table 7.10
Double-ended Substation Topologies

Number	Topology			Zone 0	Zone 1
	CB Main 1	CB Main 2	CB Tie		
1st	Open	Open	Open	0	0
2nd	Open	Open	Closed	0	0
3rd	Open	Closed	Open	0	2
4th	Open	Closed	Closed	2	2
5th	Closed	Open	Open	1	0
6th	Closed	Open	Closed	1	1
7th	Closed	Closed	Open	1	2
8th	Closed	Closed	Closed	3	3

1 Topology 0 is used for unpowered buses and may be used for maintenance purposes.
 2 Topology 1 is used when the zone is powered from Main 1.
 3 Topology 2 is used when the zone is powered from Main 2.
 4 Topology 3 is used when the bus is powered from its associated main and the tie is closed.

An association matrix for this combination of sources would look as shown in Table 7.10 and the DE Sub One-Line in Figure 7.1.

In this example, eight different topologies are possible; however, three topologies are sufficient to account for the possible energized buses and the potential sources of power for those buses, and a fourth can be used for special applications. This later one we will call topology 0. A state change is recognized by the Entellisy CPU every time a topology circuit breaker changes from closed to open, or open to closed. The CPU records an event every time there is a state change in the system.

One example of how the Entellisy CPU uses the dynamic state-change capability is potential transformer throw-over or assignment. The system provides a way to assign to each breaker the voltage transformers that sense the source that is valid at that breaker. A unique bus combination is also known as a topology for a specific zone. Table 7.11 is an example of PT assignment for the double-ended substation in the topology table example.

The mains are always associated with the PTs connected on their line side. The feeders associated PTs change depending on the combination of closed mains and ties that power the bus to which the feeder circuit breakers are connected. The net effect of

Figure 7.1

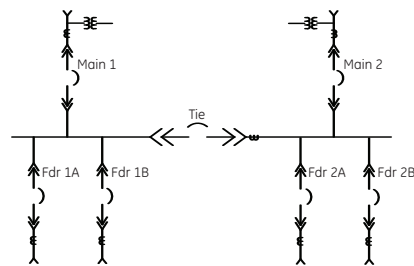

Table 7.11
PT Assignment for Each CB Based on Topology

Breaker	Topology Designation			
	0	1	2	3
Tie	None	2	2	1 or 2
Main 2	2	2	2	2
Main 1	1	1	1	1
Feeder 1A	None	1	2	1
Feeder 1B	None	1	2	1
Feeder 2A	None	1	2	2
Feeder 2B	None	1	2	2

this procedure is the same as if a hardwired PT throw-over scheme were used separately for each bus.

The unique bus combination number, 0–3, corresponds to the numbers assigned in the topology and zone-association matrix. This matrix is also used when ZSI tiers are selected and bus-differential (87B) settings are made. Dynamic state changes are used with all the multipoint protection and alarm schemes supported by the Entellisys system.

Zone-based protection provides increased flexibility over traditional time-delay-based overcurrent protection schemes. Several of the protection modes enabled by Entellisys are possible because of the system’s ability to identify both the location and magnitude of a fault. This allows faster protection, which lowers the let-through energy, and a simple implementation with complex power system configurations. Each of the zone-based protection modes is described below.

Topologies and zones are specified at the GE factory based on information provided during the order process. However, it is possible to change these afterwards if required.

Capabilities Over and Above the Traditional

Expanded overcurrent protection capabilities

The Entellisys low-voltage protection suite offers several additional optional protection configurations not easily handled by traditional systems, including:

- Integral ground-fault protection for multi-source solidly grounded systems. Ground-fault protection for main buses in double-, triple-, or quadruple-source systems with open or closed ties.
- High-resistance ground-fault detection, including a pulsing function.
- Zone interlocking for short-time and ground-fault protection, with a 25 ms minimum time band.
- Bus differential (87B), main buses, open or closed tie circuit breakers with 25 ms detection.

All of the advanced overcurrent protection modes offered by Entellisys are based on zones and topologies defined via the HMI upon installation of the equipment or by GE at the factory. Zone-based protection is more powerful, flexible, and selective than traditional time delay-based methods. Whenever a circuit breaker associated with an Entellisys Messenger does not communicate with the CPU in a recognized manner, or if one of the Messengers is in test mode, the zone-based algorithms are turned off to prevent nuisance tripping. However, all normal circuit breaker overcurrent settings are still active at the CPU for circuit breakers still communicating, while any circuit breaker that is not communicating properly is protected by the backup functions at the Messenger node. Thus, even with zone-based protection turned off, basic protection is still provided with multiple levels of redundancy.

Specific Protection Modes

Multisource ground-fault (MSGF) protection for solidly grounded systems

Entellisys can provide ground-fault protection for power systems with up to four sources divided into four zones. This function is typically used with double-ended substations in which each transformer is grounded separately or where there are standby sources independently grounded at the source, in addition to the main utility source ground. For the purposes of the MSGF zone, only the mains and ties are required in the calculations. Complete selectivity and minimum time delays are possible while sources are not in parallel. When sources are temporarily in parallel, the selectivity of the tie may be sacrificed to maintain fast protection or vice versa, depending on the user’s preference.

Figure 2 represents a possible configuration. In this example, the main bus is configured into two zones, each defined by the tie and main connected to the zone. The main and tie circuit breakers define the potential sources and exits for the zone that require monitoring for multi-source ground-fault

Figure 7.2

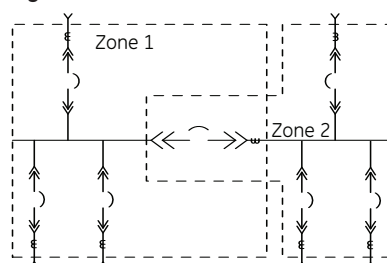

detection. The feeder circuit breakers need not be considered in the zone summation to detect which source is feeding a ground fault off each bus. The Entellisys CPU is able to identify the location of any fault within a specific zone by summing all the outgoing and incoming currents and tripping all source circuit breakers feeding into that zone at the time delay set for the zone. In a multiple-grounded system, the time-delay bands are set for the MSGF zone, not for the individual circuit breakers.

A circulating ground fault current would flow through the system and hence would not generate a result in a net residual sum. A fault on the load side of a feeder would be detected as fault within the zone. The system tracks whether a feeder is also identifying a ground fault current. When a feeder is determined to have fault current, the system determines the fault is in the feeder circuit and acts accordingly. If no feeder is detecting a fault, then the fault is in the main bus for the zone and the system trips the source circuit breakers for the zone.

The Entellisys system is able to keep track of the status of each main and tie and identify the source of fault current without the need for extra interlocking between circuit breakers, extra CTs, or extra wiring of any kind.

How multisource ground-fault protection works

The residual current for each circuit breaker is defined as

$$i_{\text{residual},k} = i_{A_k} + i_{B_k} + i_{C_k} + i_{N_k}$$

where i_{A_k} is the k th sample of phase A current and $i_{\text{residual},k}$ is the k th sample of residual current at the circuit breaker. This formula calculates the fault current for one data sample. Entellisys uses a sample rate of 64 per cycle, so this formula is valid for 1/64 of a sine wave.

Since the summation is performed for each sample and not for the calculated vector value, the Entellisys system is able to include all the current information, including the full harmonic spectrum, not just the fundamental component.

Residual current for the zone during one complete half-cycle is defined using the mean-squared residual of all the circuit breakers defined for the zone, expressed as

$$I_{\text{residual,zone}}^2 = \frac{2}{N} \sum_{k=0}^{N/2-1} (i_{\text{residual}0,k} \pm i_{\text{residual}1,k} \pm \dots \pm i_{\text{residual}M-1,k})^2$$

where N is the number of samples per cycle (64), $i_{\text{residual},k}$ is the k th residual sample, and M is the number of circuit breakers in the zone. This calculation determines the squared residual current for one half-cycle and is repeated at every half-cycle in the CPU. The number of half-cycles considered by the algorithm is proportional to the time delay.

In addition to these calculations, the algorithm includes allowances for heating and cooling and CT error.

The multi-source ground-fault detection algorithm requires identification of zones, topology circuit breakers, and topologies. This identification is made during construction of the equipment at the factory, based on an analysis of the power distribution system one-line diagram.

High-resistance ground-fault detection

The Entellisys CPU is able to detect ground faults on a power distribution system that is high-resistance grounded, whether it is resistance grounded at the source or at the main bus. Either directly grounded wye-connected transformers or delta-connected transformers grounded via an isolation transformer may be used. HRGF is optional and provides an alarm-only function. The alarm may be programmed to an Entellisys output that can, in turn, be used to trip a circuit breaker or as a logical input into the Entellisys Flex Logic engine. The CPU supports up to 30 separate HRGF functions and thus may independently monitor multiple ground resistors.

The ground resistor is programmed via HMI and may be set to 5–500 ohms, programmable in one-ohm steps. The HRGF pickup may be set at 2–10 amperes in steps of 0.1 amperes. The constant time delay for the alarm may be set at 0.5–5 seconds in steps of 0.1 seconds.

A ground CT connected to an Entellisys Messenger measures ground current through the grounding resistor. The system is able to handle one or more resistors simultaneously. Each grounding resistor is measured by its own CT and connected to a dedicated Entellisys Messenger. The system also functions with tie circuit breakers closed and with grounding resistors in parallel.

In addition, the CPU monitors phase-to-ground voltage and senses the voltage loss on the

grounded phase, allowing identification of the grounded phase.

The system logs an event when it senses a ground-fault current over the threshold or when the ground-fault current exceeds the time delay. The HRGF alarm drops out when the ground-fault current drops to 97% of the threshold. A cooling-down circuit is included in the HRGF detection algorithm to properly account for intermittent ground faults.

If the system senses a loss of phase, defined as less than 80% of nominal phase-to-neutral voltage, an event is logged and HRG detection is disabled for that phase. The Entellisys HRGF system is able to identify the faulted phase by subtracting the voltage across the resistor from each phase-to-neutral voltage.

How HRG fault detection works

The Entellisys Messengers with connected ground-current CTs are identified via the HMI. The CPU is then able to read the fault current directly from the CT, thereby identifying the magnitude of the fault current, I_G . Simultaneously, the CPU monitors phase-to-neutral voltage for each phase. For each phase-to-neutral voltage that is above 80% of nominal, the CPU compares the magnitude of the corresponding phase-to-ground voltage to a reference voltage, V_{REF} , defined as follows:

$$V_{REF} = V_{\text{phase-neutral nominal}} - I_{\text{pickup}} R_G$$

where $V_{\text{phase-neutral nominal}}$ is the nominal phase-to-neutral voltage magnitude, I_{pickup} is the programmed ground-current pickup magnitude, and R_G is the ground resistance.

If the phase-to-neutral voltage is below V_{REF} , the CPU indicates that phase as faulted, logs an event, and raises an alarm if the time-delay threshold is exceeded.

The CPU calculates the phase-to-ground voltages as follows:

$$V_{AG} = V_{AN} + I_G R_G$$

$$V_{BG} = V_{BN} + I_G R_G$$

$$V_{CG} = V_{CN} + I_G R_G$$

where V_{AG} , V_{BG} , and V_{CG} are phase-to-ground voltage phasors; V_{AN} , V_{BN} , and V_{CN} are phase-to-neutral voltage phasors; I_G is the actual ground-current phasor; and R_G is the ground resistance.

Simply stated, if the fault current exceeds the pickup current, the voltage in the faulted phase is lower than the reference voltage and thus the faulted phase can be identified.

Cautionary note: User settings resulting in I_{pickup} times R_G greater than $V_{\text{phase-neutral nominal}}$ are not valid. If such a setting is attempted, the CPU will log an event to indicate an invalid settings combination.

Zone Selective Interlocking (ZSI) - short time and ground fault

The Entellisys system provides a zone-selective interlocking function similar to that offered in many electronic trip systems. However, the Entellisys-based ZSI system offers significant improvements over the traditional method. Its capabilities include the following:

- Zone-selective interlocking for up to four zones or levels.
- Control of tripping with time bands as fast as 1.5.
- Full functionality with no extra wiring or devices.
- Operation at any programmed delay for faults within a zone of protection.
- Changing ZSI circuit breaker relationships (tiers) depending on which mains and ties are closed.
- Delay increments of 100 ms per level to achieve selectivity and maintain good backup protection.

The zones for ground-fault protection are the same as those for multi-source grounding protection. Within each zone and for each different topology, the circuit breakers are divided into tiers. Each tier represents the time-delay hierarchy required to achieve optimum protection and selectivity. Each circuit breaker may be assigned to one of four tiers within a zone. The top tier is always labeled tier 0. Next is tier 1, then tier 2, with the last and lowest defined as tier 3. Hence, in a simple radial two-tier system, the feeders are labeled tier 1 and the main is tier 0.

For substations that are operated with the tie normally-open, the tie and the mains could be set at tier 0. This will allow the tie and the mains to operate at minimum (or set) delay for a fault in their zone of protection or feeder set delay plus 100ms if the fault is below a feeder. If the substation is run from one transformer with the tie closed it may be preferable to set the tie at tier one and the mains at tier 0 to achieve tie to main selectivity.

How short-time ZSI works

In the Entellisys ZSI model, the highest-level main circuit breaker is labeled tier 0. So in a simple double-ended substation, the mains are each tier 0, the tie is tier 1, and the feeders are all tier 2. In the following explanation, the terms lower- or higher-numbered tier indicate in which direction the action is intended.

Whenever the CPU detects that a breaker in one or more of the defined ZSI zones has gone into ST pickup, it performs the following actions:

1. Based on the tier to which the circuit breaker belongs, it sets the short-time delays for all breakers with the next-lower tier number to the short-time delay time of the circuit breaker in pickup plus 100ms. Thus a breaker with a tier number of 2 sets the short-time delays of the breakers with tier number 1. Note that a breaker, for example a tie, can reside in multiple zones. However unless a circuit breaker is detecting fault current, it will not trip regardless of tier setting.
2. Each circuit breaker whose short-time delay setting was changed in step 1, sets the short-time delays for all the breakers with the next-lower tier number to the new delay, plus 100ms. For example; each tier 1 breaker whose short-time delay was changed will, in turn, change the short-time delay for tier 0 breakers in the same zone (or zones) by adding 100ms to its own delay and making that the new tier 0 delay.
3. Continue this process of changing the short-time delay of breakers in the zone with the next lower-tier number until tier 0 is reached. (Tier 0 breakers are typically mains.)
4. All modified short-time delays of the breakers in the zone are set to their original values, after all short-time elements cool off completely.

It should be noted that the ZSI system never lowers the time delay of a circuit breaker, but only increases the delays of circuit breakers with lower tier numbers than the breaker for which the short-time fault current was identified by the CPU within the same zone. The time delay of a circuit breaker is never increased past a maximum time delay of 400ms.

How ground-fault ZSI works

The algorithm for ground-fault protection is the same as short-time ZSI, except for multi-source grounded systems. A ground fault that sends a feeder below a MSGF zone into ground-fault timing increments the delay of the MSGF zone by 100ms,

which means all the circuit breakers feeding into the zone (mains and ties) are timed similarly. See the description of multi-source ground-fault protection for further details.

In a single-ground system with no ground-fault protection zones, the time delays are incremented by 100ms per tier above the tier in which the fault is sensed, in the same way as with short-time ZSI.

Zone-based overcurrent protection or bus-differential protection (87B)

Entellisys low-voltage switchgear can provide complete zone-based overcurrent protection (also known as 87B protection in ANSI relay nomenclature). The minimum setting for pickup is 20% of the CT rating of the largest circuit breaker in the zone and the maximum setting is 22,000A. Any circuit breaker feeding into a protected zone may be tripped in as little as 25ms.

The complete Entellisys zone-based bus-protection system combines differential protection and zone-selective interlocking to handle faults over a wide range of magnitudes. This combination of two different methods for detecting faults allows detection of small and large faults. Furthermore, it is not affected by CT saturation issues. The differential-protection algorithm may be set to pick up as high as 22,000 amperes or as low as 800A in a zone with a 4000A main.

The algorithm is suspended if any one current in or out of the zone exceeds ten times the CT rating for that circuit breaker. Zone-selective interlocking then takes over protection of the zone and can provide equally fast detection and tripping. Hence, in a radial system substation with a 4000A main and several 800A feeders, faults up to 39,999 amperes may be sensed by the bus-differential algorithm, while faults of 40,000 amperes and above are sensed by the short time and ZSI algorithms. For the smaller faults, the CPU trips the main circuit breaker at the set time delay for the bus-differential zone, while for the larger faults the CPU trips the circuit breaker at a time delay set for the short-time function of that main circuit breaker. Both of these time bands may be as short as 25ms. In the case of a through fault in one of the 800A feeders, the bus-differential algorithm senses faults as high as 7999A and keeps the main from tripping. For faults of 8000A and above, the CPU adds a delay to the

main circuit breaker per the tier assignments for the zone and trips the feeder circuit breaker at its set time delay, which may be as little as 25ms.

Zone-based bus protection provides optimal protection with no sacrifice in selectivity. GE's unique method uses a straightforward differential algorithm in combination with the Entellisys zone-selective interlocking to provide complete bus protection for faults from below rated current into a zone to the full short circuit rating of the equipment, with no concerns over CT saturation. Faults may be detected and circuit breakers tripped as fast as 25ms. In addition, the Entellisys zone-protection system is able to define backup breakers to be tripped in case the first circuit breakers do not clear the fault and alarm levels that may be used if tripping for low-level faults is not desired.

How bus-differential protection works

The Entellisys bus-differential algorithm is based on zones defined via the HMI. All the circuit breakers connected to each zone should be identified.

The following settings are made at the factory for each zone:

- Zone definition and member circuit breaker identification
- Current flow direction for each circuit breaker
- Primary breakers to be tripped for an in-zone fault (primary trip target)
- Backup breakers to be tripped for an in-zone fault (secondary trip targets)

These settings are recorded and fixed when the CPU is powered. If the settings are changed via the HMI, the CPU must be rebooted. If invalid settings are detected, the CPU deactivates the 87B function and records an event.

Each bus-differential function has several settings that may be individually user selected for each zone and each topology:

1. Select the TRIP or OPEN global setting for protection settings to choose whether protective functions will trip (includes lockout) or open (excludes lockout) the target circuit breakers.
2. Enable or disable for TRIP or OPEN to enable or disable the protection action selected in setting 1 for each pick or delay combination.
3. Pickup 1 for TRIP or OPEN sets the threshold for the first target circuit breakers.

4. Delay 1 for TRIP or OPEN sets the time delay for the first target circuit breakers.
5. Pickup 2 for TRIP or OPEN sets the threshold for the second target circuit breakers.
6. Delay 2 for TRIP or OPEN sets the time delay for the second target circuit breakers.
7. Backup function enabled or disabled for TRIP or OPEN for the second group of target circuit breakers for backup of the first group.
8. Backup time delta enabled or disabled for TRIP or OPEN for an additional time delay before the backup group of circuit breakers is operated if the fault current continues.
9. Enable or disable for alarm only is a global command to enable or disable alarm settings.
10. Pickup 1 for alarm only.
11. Delay 1 for alarm only.
12. Pickup 2 for alarm only.
13. Delay 2 for alarm only.

The available delay settings are the same as for the short-time and ground-fault bands. The minimum current pickup setting is 20% of the largest sensors in the zone and the highest setting is 22,000 amperes.

Calculations for the 87B algorithm

The Entellisys calculation algorithms operate on the raw digitized data obtained from the current sensors. Because of this, the mathematical operations are performed on a single sample of data from each current used in the calculation. Since the current data across the system are 100% synchronized, the calculations need not take into account the phase angle between voltage and current, and may be, strictly based, on the instantaneous current magnitudes.

During each half-power cycle the CPU calculates the mean-squared residual current for each phase of the M circuit breakers in the zone. An example of the formula for phase A is:

$$I_{\text{residual,A}}^2 = \frac{2}{N} \sum_{k=0}^{N/2-1} (i_{A,0,k} \pm i_{A,1,k} \pm \dots \pm i_{A,M-1,k})^2$$

where $I_{\text{residual,A}}$ is the residual current for phase A, N is the number of samples per half-cycle (64), M is the number of circuit breakers in the zone carrying current in or out, and $i_{A,0,k} \dots i_{A,M-1,k}$ are the k th samples of phase A circuit breakers 0 through $M-1$. The same calculation is performed by the CPU for all three phases simultaneously and adjustments for CT errors are performed for each phase and CT.

The total residual current for the three-phase system is calculated by selecting the maximum single-phase residual of the three residual currents. The subscript *adjusted* indicates that the residual currents have been adjusted for CT error:

$$I_{BD}^2 = \max(I_{residual,A,adjusted}^2, I_{residual,B,adjusted}^2, I_{residual,C,adjusted}^2)$$

If the thresholds for time and magnitude are exceeded, a command to sound alarm 1, sound alarm 2 if it is set, trip the primary targets, and eventually trip the secondary targets is issued by the CPU, as requested by the user settings.

Each residual current is provided with a cooling algorithm to allow for the thermal characteristics of the buses and integrate intermittent faults over time.

Voltage protective relays and current alarm

The Entellisys protection system provides for the following additional optional voltage-related protective functions:

- Overvoltage
- Undervoltage
- Phase loss
- Overfrequency
- Underfrequency
- Power reversal
- Synch check

In addition, the Entellisys system provides for an optional high-current alarm function that may be selected and set for each circuit breaker.

Each relay function also has the following settings associated with it:

- Alarm-only relay activated
- Alarm-only relay pickup

- Alarm-only relay drop out
- Trip/Open relay activated
- Trip/Open relay pickup
- Trip/Open relay drop out

The Trip/Open selections are not available for the high-current relay, which is intended only for alarm or logic input use. All relay calculations are performed at the CPU and not the Messengers. Because many of the conditions identified by these relays would not be cleared if the circuit breaker were opened, the system is able to handle the situation when a circuit breaker is re-closed and the condition persists. The CPU monitors the open or not-open status of a circuit breaker after the trip or open command is issued. If after 180 cycles the circuit breaker transitions to “not-open” status, and the protective relay remains in pickup status, then the trip/open command is reissued.

Many of the relays may be disabled via Flex Logic, which allows a protective relay to be turned off by a control sequence programmed in the CPU.

Table 7.12 provides a summary of the settings available for each relay function. For a more detailed explanation, see the descriptions below.

Undervoltage relay

Undervoltage protection compares the sensed voltage against a threshold. In wye systems, the rms phase-to-neutral voltage is used, while in delta system the rms phase-to-phase voltage is used. The relay has the following capabilities and characteristics:

- Fixed and inverse time curves
- Pickup adjustment range from 50 to 95% of nominal in 1% increments

Table 7.12
Available Relay Function Settings

Capability	Overvoltage	Undervoltage	Underfrequency	Overfrequency	Phase Loss	Power Reversal	High Current	Synch Check
Alarm	Yes	Yes	Yes	Yes	Yes	Yes	Yes	Yes
Trip/Open	Yes	Yes	Yes	Yes	Yes	Yes	No	Yes
Pickup	105–125% 1%	50–95%	50–60 Hz, 0.1 Hz ²	50–70 Hz, 0.1 Hz ³	8–50%, 1%	10–990 kW 10 kW	50–200% LTPU 5% ⁴	0–90 V, 0.5 V, 0.2 Hz, 0.1 Hz, 0–60 D, 1D
Accuracy	±2%	±2%	±0.1 Hz	±0.1 Hz	±2%	±2%	±10%	±2%
Time delay	0.5–600 s, 0.5 s	0.5–600 s, 0.5 s ¹	0.5–600 s, 0.5 s	0.5–600 s, 0.5 s	0.5–600 s, 0.5 s	0.5–600 s, 0.5 s	1–15 s, 1 s	N/A
Accuracy	±0.1 s	±0.1 s ¹	±0.1 s	±0.1 s	±0.1 s	±0.5 s	±1 s	N/A
Drop out	97% Threshold	103% Threshold	103% Threshold	97% Threshold	97% Threshold	97% Frequency	97% Threshold	None
Blocking Voltage	None	5–75%	5%	5%	5%	None	None	Dead Bus
Flex logic control	Yes	Yes	Yes	Yes	Yes	Yes	Yes	Yes

¹ The undervoltage relay has the capability for a fixed or inverse time delay. The accuracy of the inverse time delay is ±4%.

² Pickup may occur at no more than 10 Hz below the nominal system frequency and never below 45 Hz. The setting range on 50 Hz systems is 45–50 Hz.

³ Pickup may occur at no more than 10 Hz above the nominal system frequency, which is 70 Hz for 60 Hz systems and 60 Hz for 50 Hz systems.

⁴ LTPU = long-time pickup setting. This relay is for alarm use only.

- Delay setting range of 0.5 to 600 seconds in increments of 0.5 seconds
- Selection of sensitivity to one, two, or all three phases below the threshold
- Relay drop out at 103% of the set pickup level
- Blocking voltage enable setting
- The undervoltage function is disabled if the voltage drops below the blocking voltage
- Ability to work with multiple potential transformers in different topology configurations per topology PT assignments
- Pickup accuracy of $\pm 2\%$

If the fixed-time curve is selected, then the relay function trips the selected circuit breaker or activates the alarm if the monitored voltage is less than the threshold for the specified time delay. The timing accuracy is ± 0.1 second.

The inverse-time curve relates the selected time delay to the voltage under the pickup threshold as:

$$T = D / (1 - V / V_{\text{pickup}})$$

where T is the operating time, D is the delay setting, V is the sensed voltage, and V_{pickup} is the pickup voltage.

Once the overvoltage threshold has been exceeded and the relay starts timing, incrementing the count will stop if the voltage reaches 100% of threshold again and will start decrementing per the cooling algorithm when the voltage reaches 103% of the set threshold.

Overvoltage relay

The overvoltage relay function works like the undervoltage relay, except that the thresholds are voltages above the nominal system voltage and only a fixed time-delay setting is available. The pickup setting range is adjustable from 105% to 125% of nominal in increments of 1%. The overvoltage relay drops out of pickup when the sensed voltage drops to 97% of the threshold setting. A cooling function decrements the accumulator.

Phase-loss relay

The phase-loss relay function has the following characteristics:

- Pickup is at 8–50% of the nominal voltage, adjustable in increments of 1%
- Time delay is 0.5–600 seconds, adjustable in increments of 0.5 seconds
- Pickup accuracy is $\pm 4\%$

- Trip-time accuracy is ± 0.1 seconds
- Drops out with the cooling circuit if the imbalance drops below 97% of the setting
- May be blocked by enabling blocking voltage, fixed at 5%
- May be disabled by Flex Logic controls

The phase-loss relay works by comparing the nominal voltage to the calculated negative-sequence voltage for the fundamental voltage waveform. The phase-loss relay function works for circuit breaker with the voltage signal assigned to that circuit breaker. The voltage input may change from topology to topology as the PT assignment to buses changes. The negative phase-sequence voltage is used whether the PT configuration is delta or wye.

The negative-sequence voltage is only calculated for the fundamental component. In addition, the relay may have a blocking-voltage enabled. The blocking voltage is fixed at 5%. If the negative-sequence voltage falls below 5% with blocking enabled, the relay stops timing and resets without cooling.

Negative phase-sequence voltage is calculated as follows:

$$V_N = \frac{1}{3}(V_{ab} + 1<240^\circ V_{bc} + 1<240^\circ V_{ca}) \text{ for ABC rotation}$$

$$V_N = \frac{1}{3}(V_{ab} + 1<240^\circ V_{ca} + 1<240^\circ V_{bc}) \text{ for ACB rotation}$$

If the unbalance decreases to 97% or less of the programmed threshold, the relay stops timing and the accumulated count decrements according to a cooling algorithm.

Underfrequency relay

The underfrequency relay function has the following characteristics:

- Pickup (60 Hz systems) is at 50–60 Hz in 0.1 Hz increments
- Pickup (50 Hz systems) is at 45–50 Hz in 0.1 Hz increments
- Time delay is at 0.5–600 seconds, adjustable in increments of 0.5 seconds
- Pickup accuracy is ± 0.1 Hz
- Trip-time accuracy is ± 0.1 seconds
- May be blocked by enabling the blocking voltage, fixed at 5%. Blocking voltage accuracy varies with frequency variation from $\pm 2\%$ at 0 Hz to $\pm 15\%$ at 10 Hz
- May be disabled by Flex Logic controls

The underfrequency relay may be enabled for each circuit breaker and works with the voltage signal assigned to that circuit breaker for each different topology. The underfrequency relay drops out of pickup and stops timing if the frequency exceeds 103% of the pickup setting. A cooling algorithm decrements the accumulator. If the sensed voltage reaches the blocking level of 5% of nominal voltage, the relay stops timing and is immediately reset.

Overfrequency relay

The overfrequency relay function has the following characteristics:

- Pickup (60 Hz systems) is at 60–70 Hz in 0.1 Hz increments
- Pickup (50 Hz systems) is at 50–70 Hz in 0.1 Hz increments
- Time delay is 0.5–600 seconds, adjustable in increments of 0.5 seconds
- Pickup accuracy is ± 0.1 Hz
- Trip-time accuracy is ± 0.1 seconds
- May be blocked by enabling the blocking voltage, which is fixed at 5% of the nominal voltage. Blocking voltage accuracy varies with frequency variation from $\pm 2\%$ at 0 Hz to $\pm 15\%$ at 10 Hz
- May be disabled by Flex Logic controls

The overfrequency relay may be enabled for each circuit breaker and works with the voltage signal assigned to that circuit breaker for each different topology. The relay drops out of pickup and stops timing if the frequency drops below 97% of pickup. A cooling algorithm decrements the accumulator. If the sensed voltage reaches the blocking level of 5% of nominal voltage, the relay stops timing and is immediately reset.

Synch check relay

The synch check relay function may provide up to six synchronism supervisory functions. Unlike the other relays, which use voltage as an input, the PTs assigned to the synch check relay do not change with topology changes and thus the two voltages used for each synch check function are fixed when they are selected.

For each synch check function the following settings must be made:

- Bus-1 voltage source
- Bus-2 voltage source
- Maximum voltage differential allowed between

voltage sources; may be set at 0–90v in increments of 0.5v.

- Maximum frequency differential allowed between buses; may be set at 0–2 Hz in increments of 0.1 Hz.
- Maximum phase-angle differential allowed between buses; may be set at 0–60 degrees in increments of 1 degree.
- Bus 1 live-bus threshold is the voltage above which the bus is considered to be live, programmable at 50–100% of the nominal PT rating, in 1% increments. The line-neutral voltage is used with wye systems and phase-phase with delta systems.
- Bus 2 live-bus threshold functions like bus 1 with a separate adjustment.
- Bus 1 dead-bus threshold is the voltage below which the bus is considered to be dead, programmable at 5–50% of the nominal PT rating, in 1% increments. The line-neutral voltage is used with wye systems and phase-phase with delta systems.
- Bus 2 dead-bus threshold functions like bus 1 with a separate adjustment.
- Configurations under which the “Dead Source” status is set to true:
 - None – dead source function is disabled
 - LV1 and DV2 – Voltage source 1 live and voltage source 2 dead
 - DV1 and LV2 – Voltage source 1 dead and voltage source 2 live
 - DV1 or DV2 – Voltage source 1 dead or voltage source 2 dead
 - DV1 or DV2 – One voltage source is dead, the other is live
 - DV1 and DV2 – Both sources are dead

Note that a source is considered dead when all phase voltages are below the dead-bus threshold. When all phase voltages are above the live-bus threshold, a source is defined as energized.

Each synch check function verifies that the two sources have equal programmed PT primary voltage and configuration (delta or wye). If both parameters are not the same for both sources, the CPU logs an event and disables that synch check function. The synch check function applies a 3% hysteresis factor to the voltage, frequency, phase, live-bus, and dead-bus thresholds.

Each synch check function provides the following status information:

- Synchronous Live – true if all three phases at both sources are above the live-bus threshold

and in synchronism (i.e., all three phases satisfy the programmed voltage, frequency, and phase differential criteria), false otherwise.

- Dead Source – true if the programmed dead-bus configuration condition is true.
- Close – true if Synchronous Live is true or Dead Source is true.

The relay function may be suspended with Flex Logic.

Entellisys Low-Voltage Switchgear Section 8. Metering

Entellisys meets metering requirements for a wide variety of customer needs, including:

- rms current and voltage
- energy, power, and power factor
- power demand
- harmonic data

There are four levels of metering available:

- Basic Metering for simple monitoring
- Expanded Metering for energy monitoring
- Demand Metering for measuring energy consumption
- Harmonic Metering for waveform and harmonic analysis

The displayed rms values are averages over 1 second (i.e., 60 cycles fundamental for a 60 Hz power system) as total rms values, including harmonics.

Basic Metering

The Basic Metering package is included with all Entellisys systems. Basic Metering includes rms current per phase (I_A , I_B , I_C , and I_N) and rms voltage per phase. On three-phase, four-wire systems, the PTs are wye connected and Entellisys provides line-to-neutral (V_A , V_B , and V_C) and line-to-line (V_{AB} , V_{BC} , and V_{CA}) voltages. In three-wire systems, the PTs are delta connected and only line-to-line voltages are provided.

Basic Metering quantities are typically displayed on the one-line diagram, if so configured. Figure 8.1 shows a one-line diagram that displays the rms currents at each circuit breaker and the rms voltages at the main bus.

Figure 8.1
One-line Diagram

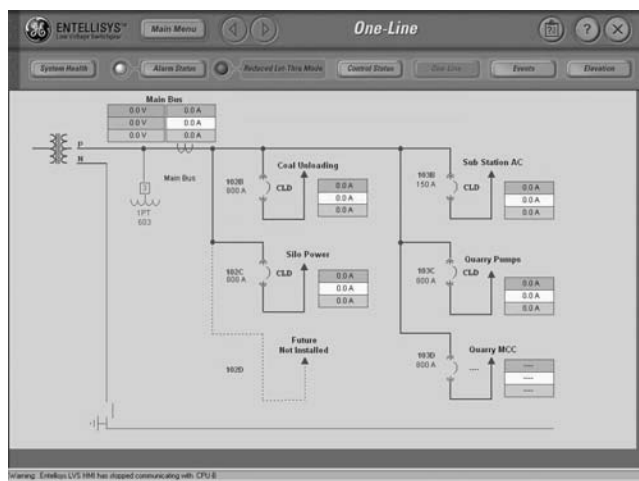

All metering data in the basic and optional levels can be viewed by clicking on the circuit breaker of interest in the one-line diagram, which displays a screen similar to that shown in Figure 8.2. This screen provides access to all information associated with the selected circuit breaker via the navigation buttons.

Detailed Metering

Expanded or Detailed Metering is the first level of optional metering features in Entellisys. You select the number of Detailed Metering packages in each system, which can be from zero to the maximum number of circuit breakers in the lineup. With this selection, energy (usage and consumption), power, and power factor can be precisely tracked for every circuit breaker that has the function enabled. This information may be useful in tracking facility process variations, allocating utility costs, and understanding energy costs.

The following quantities can be metered with this option (*note that per phase quantities are only available for wye-connected systems*):

- Positive watt-hours, per phase and three phase total
- Negative watt-hours, per phase and three phase total
- Positive varhours, per phase and three phase total
- Negative varhours, per phase and three phase total
- Apparent voltamperehours, per phase and three phase total
- Real power (watts) per phase and three phase total
- Reactive power (vars) per phase and three phase total
- Apparent power (voltamperes) per phase and three phase total

Figure 8.2
Circuit Breaker Status Screen

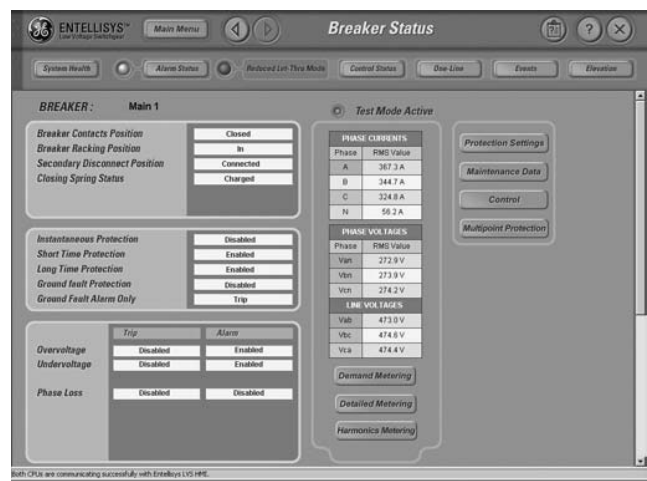

- Power factor of each phase and three phase total
- Minimum power factor, including date and time, per phase and three phase total
- Maximum power factor, including date and time, per phase and three phase total

Energy values for watthours, varhours, and voltamperehours are summed starting either from the time that this option was last applied or since the last time the values were reset through the human-machine interface (HMI). Real, reactive, and apparent power quantities are averaged over one second and include the fundamental frequency and harmonics. Power factors are calculated by dividing real power by apparent power.

Watts and watthours are positive when the current is flowing from line to load and negative when the current is flowing from load to line. Vars and varhours are positive when the current is lagging the voltage and negative when the current is leading the voltage. Power factor is positive (i.e., lagging) when watts and vars have the same signs and negative when watts and vars have opposite signs. Minimum and maximum comparisons are based on magnitudes; e.g., a power factor of -0.866 is greater than a power factor of 0.707.

You can view the Detailed Metering screen by clicking the Detailed Metering button on the Circuit Breaker Status screen. An example of the Detailed Metering screen is shown in Figure 8.3. Note that the Detailed Metering button is active only if the Detailed Metering option has been enabled for that circuit breaker.

Figure 8.3
Detailed Metering Screen

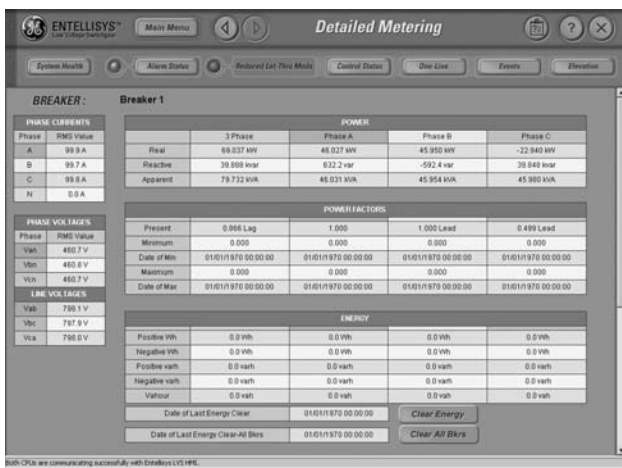

The Clear Energy button resets the real, reactive, and apparent energy values and the minimum and maximum power factors for the circuit breaker being viewed. The Clear All Bkrs button resets the energy and power factor values for all the circuit breakers. Entellisys keeps track of how many times the energy values have been reset, along with the dates and times of the resets.

Demand Metering

Demand Metering is the second level of optional metering available in Entellisys. It includes all energy and power values in the Expanded Metering option plus additional demand values. Again, you can have any number from zero up to the maximum number of circuit breakers in the lineup of Demand Metering packages in the system. Metered demand information allows identification of peak and minimum power usage on circuit breakers in the Entellisys system along with power-usage profiles. This is key information for managing your electric power costs. The Demand Metering option provides the following quantities:

- All quantities available with the Expanded (Detailed) Metering option
- Previous-interval kilowatt (kW) demand
- Maximum kW demand
- Previous-interval kilovar (kvar) demand
- Maximum kvar demand
- Previous-interval kVA demand
- Maximum kVA demand
- Demand logging: kWh, kvarh, kVAh, kW demand, kvar demand, kVA demand, power factor

Table 8.1
Valid Interval and Subinterval Combinations

Subintervals per Interval	Subinterval Length, Minutes										
	1	2	3	4	5	6	10	15	20	30	60
1 (Block Demand)	X	X	X	X	X	X	X	X	X	X	X
2 (Rolling Demand)	X	X	X		X	X	X	X		X	
3 (Rolling Demand)	X	X		X	X		X		X		
4 (Rolling Demand)	X		X		X			X			
5 (Rolling Demand)	X	X	X	X		X					
6 (Rolling Demand)	X	X			X		X				
10 (Rolling Demand)	X	X	X				X				
12 (Rolling Demand)	X				X						
15 (Rolling Demand)	X	X		X							

In general, a demand value is the average power used over a specified demand interval. Demand intervals are normally a fraction of an hour that results in a whole number when divided into 60 minutes. For example, a 12-minute interval is a valid demand interval, since 60 divided by 12 is 5, a whole number. For metering systems that have a system clock, such as Entellisys, one of the interval boundaries is synchronized to the start of each hour. This is why the specified interval duration must be a whole number when divided into 60 minutes.

Entellisys supports both block demand and rolling demand interval calculations, as noted in Table 8.1. By definition, a block demand interval consists of only one subinterval. Block demand is the average power used during a single interval. A rolling demand interval consists of two or more subintervals within each demand interval.

For block demand, Entellisys calculates the average power over the duration of each specified demand interval, *I*. For rolling demand, Entellisys performs a demand calculation at the end of each subinterval for the previous *N* subintervals, where *N* is the number of subintervals per demand interval. (Note that *N* is always a whole number.) The calculation is performed for all demand values noted above in the Demand Metering option. Demand log entries are added at the end of each demand interval or subinterval.

In Entellisys, groups of demand intervals (as well as subintervals) are synchronized to the hour boundary. For example, if the demand interval

length is 15 minutes, the demand intervals end on the hour and at 15, 30, and 45 minutes past the hour. The programmed interval length (block demand) or subinterval length (rolling demand) and number of subintervals per demand interval apply to all circuit breakers at which demand metering is enabled. Figure 8.4 illustrates the data presented when the Demand Metering button is clicked for a circuit breaker that has this metering option. This screen also provides access to the setup, data reset, and log-clearing functions for a particular circuit breaker.

Figure 8.5 is an example of a demand log file. The demand log charts the demand, power factor, and energy use versus time. You can view specific log data for a given time by moving the cursors with the sliding bars at the top of the window. The *Save to USB* button saves the demand log file to a USB drive.

A log viewer setup screen is accessed by clicking on the *Config* button. Entellisys keeps track of how many times the demands and the demand logs have been reset, along with the dates and times of the last resets.

Harmonic or Power Quality Metering

Harmonic (or Power Quality) Metering is the third-level metering option available with Entellisys. This option includes all metering functions in Demand Metering and Expanded Metering, plus those that allow the monitoring of essential power quality data. With the harmonic distortion, harmonic content, and power factor information, potentially harmful overheating resulting from excess harmonic content

Figure 8.4
Demand Metering Screen

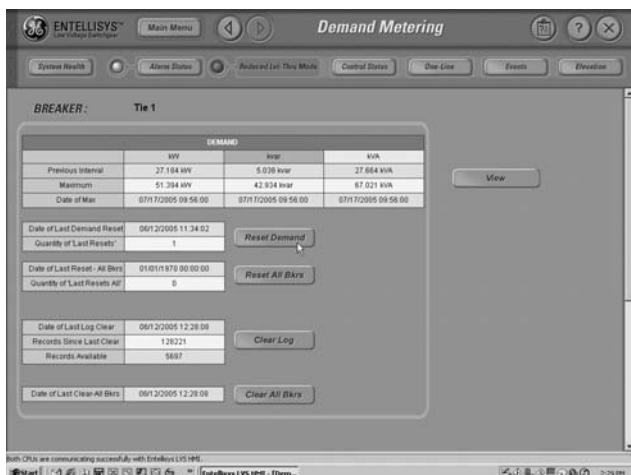
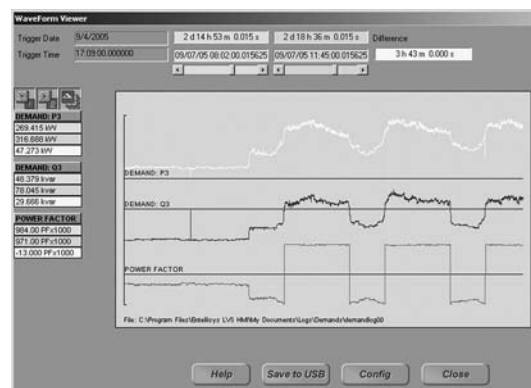

Figure 8.5
Demand Log Viewer



can be identified and corrected. Like the previous two metering packages, you can have from zero to as many Harmonic Metering packages as circuit breakers. Harmonic Metering provides the following quantities:

- All quantities available with the Demand Metering option
- K factor for each current phase
- Voltage Total Harmonic Distortion (VTHD) for each phase
- Current Total Harmonic Distortion (ITHD) for each phase
- Frequency spectrum (magnitude only) for each voltage and current phase

Entellisis waveform analysis collects 64 samples per cycle, so it can accurately calculate and display harmonic content up to the 31st harmonic (based on a fundamental system frequency of 60 Hz). You can view the Harmonics Metering screen, as shown in Figure 8.6, by clicking on the *Harmonics Metering* button on the Circuit Breaker Status screen.

Click on the *Harmonics Analysis* button to view the frequency spectra of the voltages and currents, as shown in Figure 8.7.

Figure 8.6
Harmonics Metering Screen

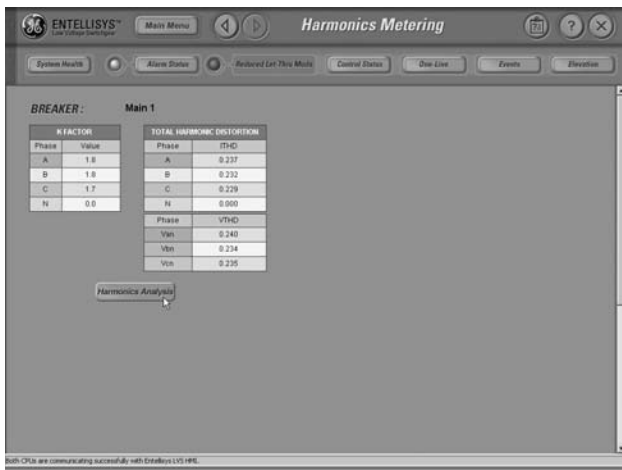
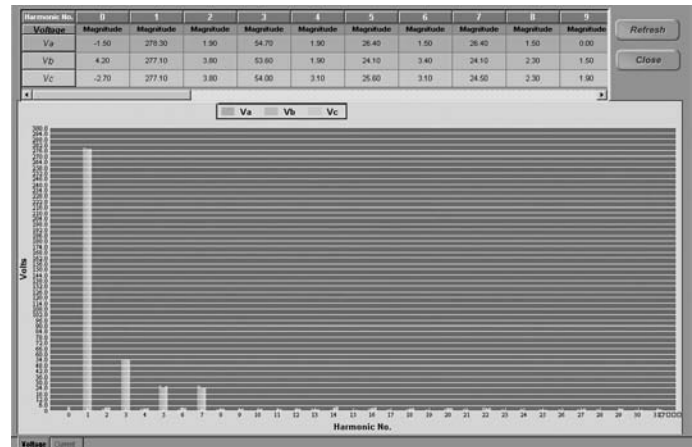

Figure 8.7
Frequency Spectra for Voltage



Accuracy

The total system accuracy has not traditionally been considered in most accuracy discussions regarding discrete devices. It is vital to consider the sensor accuracy when analyzing metering accuracy. The Entellisys total system accuracies reflect both the sensors and the electronics.

Table 8.2 lists the metering accuracies for energy and power values (Wh, varh, VAh, W, var, and VA) under the following conditions:

- Nominal frequency
- Nominal voltage
- Power factor of 0.85 to 1.00 for Wh and VAh
- Power factor of 0.00 to 0.15 for varh.

See Tables 8.3 and 8.4 for data on voltage and current accuracy at nominal frequency.

Setup

Metering setup requires four elements: basic configuration, packages selected, programmable parameters, and meter distribution.

Basic Configuration

The information required for the Basic Configuration ensures that metering operates correctly and accurately. Some of this information is also used to set up other functions, such as overcurrent protection and protective-relay functions. The frame and CT ratings, power-flow direction, PT configuration, and Reference PT for each circuit breaker are available on the User Settings > Metering & Waveforms screen. An example is shown in Figure 8.8. Entellisys also requires the current-flow direction for each circuit breaker. This defines the line-load reference that determines positive and negative power flow.

For all Entellisys metering quantities that require voltage, the potential transformer (PT) information and power system configuration (i.e., nominal voltage and power system configuration as three-phase, four-wire wye or three-phase, three-wire delta). Since PT information is common to all circuit breakers in the Entellisys system, Entellisys does not require this to be entered for each circuit

Table 8.2
Metering Accuracy

Current (percent of nominal CT rating)	Energy and Power Accuracy (percent of reading, includes current sensors)
10%	±5.0%
30%	±4.5%
50%	±4.0%
75%	±3.0%
85-100%	±2.0%

Table 8.3
Voltage Accuracy

Current (percent of nominal CT rating)	Voltage Accuracy (percent of reading, includes voltage sensors)
50%	±2.0%
75%	±1.5%
85-100%	±0.8%

Table 8.4
Current Accuracy

Current (percent of nominal CT rating)	Current (percent of reading, includes current sensors)
10%	±3.5%
30%	±3.25%
50%	±2.75%
75%	±1.75%
85-100%	±0.8%

Figure 8.8
Configuration Information for Metering



breaker. The voltage information supplied by one circuit breaker can be used for calculations for other circuit breakers. Refer to the Entellisys instruction book for additional setup information.

Packages Selected

You select the number and type of metering packages desired in the Entellisys system and this capability is programmed at the factory during manufacturing. Once the system is at the facility, new or additional packages can be added by contacting the factory, who will send you the information necessary to upgrade the CPUs. It is not necessary to add current transformers, wiring, or devices to add or change metering packages.

Programmable Parameters

The only programmable parameters for metering are the demand interval or subinterval length and the number of subintervals per interval. This information is set in User Settings > Metering & Waveforms > Demand. An example is shown in Figure 8.9.

Meter Distribution

One of the unique features of Entellisys is that metering functions can be moved from one breaker to another, or Mobile Metering. The assignment of the metering functions is defined in User Settings > Metering & Waveforms > Demand screen, as shown in Figure 8.10. The metering functions can be moved to where they are needed by a user with the correct authority. For instance, if there are three harmonic packages and, under normal conditions, are located on the main and tie circuits, and then a feeder experiences peculiar behavior, a Harmonic Meter package could be easily moved to the feeder for the duration needed by simply touching parameters on a screen. The meter can just as easily be moved back to the main or tie after the appropriate amount of data is collected on the feeder circuit. With Entellisys, meters are a dynamic function and a real tool that can be moved when and wherever needed.

Figure 8.9
Configuring Demand Calculations

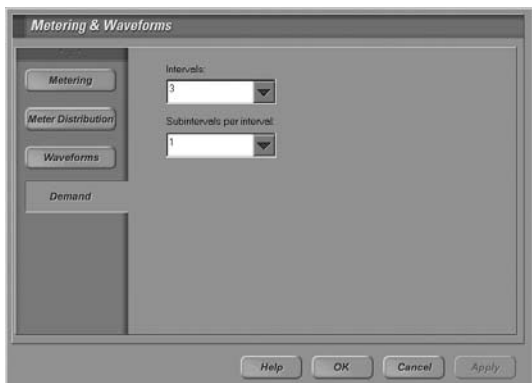
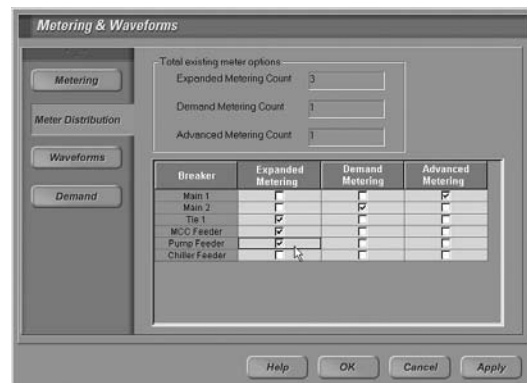

Figure 8.10
Meter Distribution



Entellisys Low-Voltage Switchgear Section 9. Events and Diagnostics

The Entellisys system performs power system and circuit breaker protection, power system control and operation, and system monitoring. To track its comprehensive capabilities and actions, the Entellisys system provides several comprehensive, coordinated monitoring functions:

- Sequence of Events
- Alarming
- System Health Monitoring

In other sections of this publication, the Entellisys protection, control, and metering functions are discussed in detail. Events from protection and control, internal diagnostic events, and data from metering can be logged by the Entellisys system, either automatically or manually. This capability provides a comprehensive view of power system activity with excellent resolution. Supplementary information from the waveform capture (WFC) function can be triggered, recorded, and associated with specific system events. This comprehensive record helps you to understand what has happened with sub-millisecond resolution. You can also analytically view event data to better understand the exact nature of power system occurrences.

For example, not only can you determine the precise moment when an overcurrent fault occurred, but you can also see the resulting automatic protection operations and follow-on operator actions. You can then analyze the effects on the power system via the captured waveform and fault report data just before, during, and just after the fault. The detailed information in the record assists in the post-mortem analysis of the system occurrence.

This information can provide substantial insight as to why facility operations were affected and what can be done to prevent or limit the effects of future power system faults. In overcurrent fault situations, not only can affected circuits see extreme current levels, but voltage depressions occur, affecting other equipment and operations. The Entellisys system's events and diagnostics capabilities work together to bring you a comprehensive overview of power system activity, providing improved management of phenomena and their effects on facility operations.

The software algorithms for protection, control, and monitoring run independently of one another. Each algorithm has its own cycle time. If a reportable event or change of status occurs as a result of the cycle completion, that event is time tagged and stored in that computer's nonvolatile memory. Consequently, the accuracy of the time tag is related to the length of the algorithm cycle that reported it. The computer clock resolution is equal to or better than five microseconds.

Figure 9.1 is a simple functional block diagram showing the interrelations between the various event generators and monitoring systems. Protection and control (automatic and manual) events can be configured as reportable events in the Sequence of Events (SOE) monitoring algorithm. The Entellisys system alarms and the internal System Health algorithms monitor events that can also be reported as SOE events. The resulting time-tagged log precisely lists all events from Entellisys monitoring, control, and protection functions.

Figure 9.1
Events and Diagnostics Functional Diagram

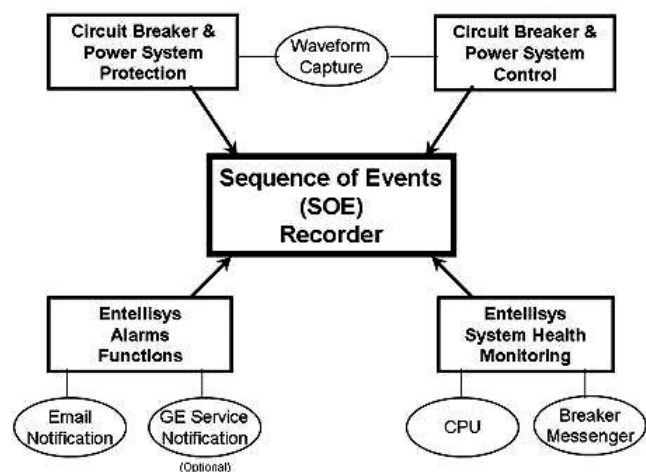

Sequence of Events

The Sequence of Events (SOE) record in the Entellisys low-voltage switchgear provides a detailed chronology of all system phenomena, as shown in Figure 9.2. This includes events related to protective and control functions as well as the monitoring system itself. Reported events are captured and time tagged to within five μ s of their reporting, then logged. The Entellisys local and remote human-machine interfaces (HMIs) continuously poll each CPU and retrieve this information automatically as new events are generated and logged. Additionally, the HMIs also log events related to them (i.e., operator logon and time synchronization) and add them to the locally stored record.

Each CPU buffers and maintains the last 1024 events it records. These event buffers are backed up in nonvolatile memory. CPU-logged events are scanned by the local HMI computer and logged in the SOE.

Some events trigger a Waveform Capture (WFC) and Fault Report (FR) data capture. These events include protection events, alarms, and control commands issued to open or close a circuit breaker. The WFCs and FRs are linked to SOE events to make it easy to recall this supplemental information when viewing a given event. Like event data, fault report data are stored in nonvolatile memory. WFC records are stored only in volatile memory within the CPU due to limited hard drive space and the potential size of WFC data. The HMI retains all retrieved WFC records on its hard drive. To maintain

system performance, the HMI does not automatically retrieve every waveform, but only those that are requested for viewing. It is possible to configure an external SCADA system, linked to Entellisys, to perform automatic WFC retrievals for backup purposes. It is also possible to download WFC data to a memory stick via the USB port on the front of the HMI.

Clicking on the header of any column in the SOE screen causes the events to be sorted according to that header. The default view of the SOE displays the events of the CPU in the order in which they were logged.

Navigation buttons are provided on the screen to move between pages of events. The screen is not refreshed automatically so that it does not interrupt navigation between pages. Instead, a refresh button is provided at the top of the screen to update the list when necessary.

If a protection or circuit breaker operation event occurs, a Fault Report and Waveform Capture associated with the event will be available. To view either of these, highlight the event and click on either the View Fault Data or Waveform button at the top of the SOE screen.

The Fault Report screen consists of a table of all circuit breakers in the system with the RMS current recorded by each circuit breaker’s Messenger in the half-cycle just before the event is shown for each circuit breaker.

Figure 9.2
Sequence of Events Screen



The SOE configuration screen can be opened by clicking the Preferences button at the top of the SOE window. The options here allow you to customize the information retained and displayed to meet your needs. The following configurations can be selected:

- **Events Filter**– Select which events are displayed in the SOE. Events not selected for display are still maintained in nonvolatile memory. These can be viewed at any time by selecting the appropriate type of event in the filtering list.
- **Protect vs. Overwrite** – In Protect mode, the event logger stops recording events if the maximum size of the daily log is reached. In Overwrite mode, the oldest events are overwritten on a FIFO basis, if the maximum size of the daily log is reached. Thus, the newest log information is always available in the log.
- **Event Log Size** – This specifies the maximum size of the daily log.
- **Maximum Fault Reports** – This specifies the maximum number of Fault Reports the HMI retrieves and stores in a given day.
- **Retention Days** – The number of days event records are retained before automatic deletion to manage hard drive space.

Waveform Capture

All waveform captures are performed for the *entire Entellisys system*. This means that all available channels configured for recording are recorded simultaneously for each waveform capture. The following channels at each point are recorded:

- Analog – $I_a, I_b, I_c, I_n, V_a, V_b, V_c$ (or V_{ba}, V_{bc}, V_{ca} for delta-connected PTs)
- Command (Control) Transitions – Open, Close, and Trip
- Status (Operation) Transitions – Open, Closed, Spring Charge, Analog IOC, Backup Trip

The capture duration is 1.0 second on 60 Hz systems and 1.2 seconds on 50 Hz systems. Up to 64 digital samples are recorded per cycle. All channels for the entire system are time synchronized to within 5 μ s of each other.

Up to 1000 system-wide waveforms can be held in memory. Therefore, the maximum number of WFC events held at any time is dependent on the number of Messengers in the system; there is one Messenger for each circuit breaker in the system. The number of WFC events that can be stored, can be calculated as the integer quotient of $1000/n$, where n is the total number of Messengers in the system. The file data are stored according to the format defined by COMTRADE (IEEE Std. C37-111-1999).

Waveform captures are viewed using the HMI screen. To see the waveform data, highlight the event of interest on the SOE list and then click the Waveform button.

The waveforms in Figure 9.3 were captured from and associated with an overcurrent event. The date and time of the waveform capture are displayed

Figure 9.3
Waveform Capture Screen

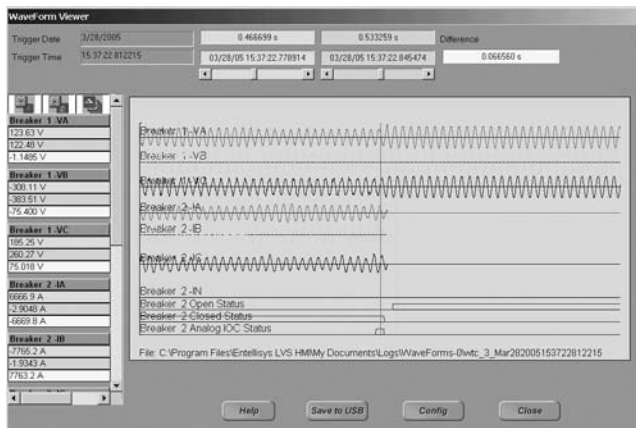

at the top of the screen. While the time resolution is displayed to the nearest microsecond, the system clock resolution is equal to or better than five μ s. Data associated with the cursors on the analog waveform chart are displayed below the date and time. To the right of the date and time are the slide-bar controls for the moveable cursors and the time data for the cursor relative to the start of the WFC event. The slide bars can be used to control the moveable cursor positions or the actual cursor on the analog waveform chart can be clicked and dragged to another location. The color-highlighted box beneath the slide control shows the length of time from the start of the record to the cursor. The color highlights correspond to the blue and green cursors on the analog waveform chart. The time difference, Δt , between the blue and green cursors is displayed in the yellow highlighted box. The red cursor on the analog waveform chart remains fixed at the time of the event trigger.

The instantaneous values from the analog waveform chart are listed in the table to the left of the analog waveforms. This is a dynamic table. The color-highlighted values correspond to the instantaneous values at the blue and green cursor locations.

These are not rms values, but the instantaneous values at those points on the analog waveform, as shown in Figure 9.4. The yellow-highlighted value is the difference between the blue and green values.

Figure 9.4
Instantaneous Values

Channel	Value
Breaker 2 -IA	7296.0 A
7216.55 A	
7612.4 A	
Breaker 2 -IB	17872 A
186.63 A	
18067 A	
Breaker 2 -IC	1179.6 A
30.938 A	
-11462.5 A	
Breaker 2 Trip Command	High
Low	Lo -> Hi
Breaker 2 Open Status	Low
High	Lo -> Hi

You can move the blue and green cursors to different positions on the analog waveform chart to determine values at any time during the recorded event. Thus, if you want to see the decline in fault current magnitude over a time period from fault inception, position the blue cursor at the beginning of the fault and the green cursor at the end of the time period. This sets the values in the table at the beginning and end of the period and the magnitude difference between them. (Please note that for sinusoidal wave forms, the cursor should be placed at the same point on the sine wave, e.g., a positive peak, to obtain meaningful Δt information.)

Located just above the Instantaneous Values table are blue, green, and yellow buttons. These buttons can be used to filter the displayed values by turning them on or off. The default position of the buttons is on. When turned off, the corresponding values are not displayed in the numerical chart.

Figure 9.5 shows the configuration screen for selecting values to be charted. Up to 40 channels can be plotted in various colors, line styles, and groups for simultaneous display. These 40 channels can be a combination of analog and digital channels. A section of waveform(s) may be selected and zoomed in on by right-clicking the mouse and dragging the outline box over the desired segment. Multiple zooms are also possible. With this function, right-clicking without dragging zooms out. Waveforms may be

Figure 9.5
Waveform Configuration Screen

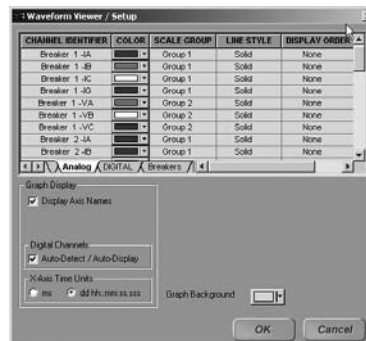

superimposed by selecting and dragging them with the left mouse button.

It is also possible to group oscillography waveform signals together to view with a common scale. Phase waveform magnitudes that are grouped within the same group heading are displayed in relation to each of the other signals in their group. The waveform with the largest amplitude is taken as the reference scale, and other waveforms will be displayed in their proper ratios with respect to this signal.

Alarms

The Alarm function provides a convenient method for creating alerts for conditions that may warrant the immediate attention of facility operators. In setting alarms, you can use the Entellisys system to automatically watch for issues or conditions that are of specific interest to the operational staff, such as identifying when the current on a given feeder is too high or too low. The main alarm status display is shown in Figure 9.6.

A single indicator light, located at the top of the screen next to the Alarm Status button, is an alert to changes in the status of any configured alarms on a “most severe” basis. Click on the button to display the more detailed Alarm Status Dialog, shown in Figure 9.7.

Selecting the condition to be monitored from the drop-down menu creates an alarm. Up to 24 individual

conditions may be selected, along with the desired email notification recipients for that condition. As shown in the sample list, an alarm may be a specific condition at a particular circuit breaker location or a general condition across any of the breakers.

Select the Email Preferences button to configure the SMTP Server to be used for email notifications. A Test Email Address button is provided. A special field for specifying Email Notification for the occurrence of control power events is also available. Control power events can be associated with the uninterruptible power supplies that power the Entellisys control power network and may be used to warn of potential control power loss system issues.

The legend across the top of the screen in Figure 9.6 shows the possible states for Alarm Conditions.

An optional notification service notifies GE Service, allowing them to respond with assistance. Maintenance and service contracts are available to support your facility’s needs. Please contact your local GE Sales Representative for more information about this offering.

System Health

The System Health Summary window, as shown in Figure 9.8, displays diagnostic information about the Entellisys monitoring system itself. Events from this information can be configured to appear in the SOE and/or the system alarms. Prompt system

Figure 9.6
Alarm Status Display

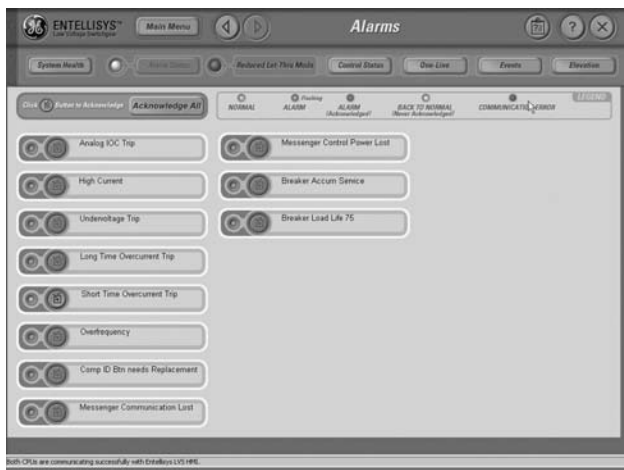
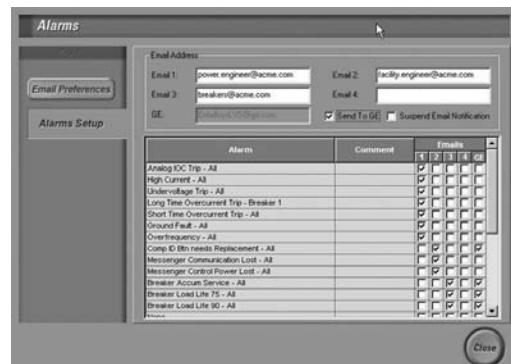

Figure 9.7
Alarm Set-up Dialog



notification of Entellisis system conditions alerts facility staff so they can act accordingly.

The System Health Summary screen contains a high-level summary of the functional status of each of the Messengers and CPUs in the Entellisis system.

Clicking on either of the CPU indicator lights will show the status for that device in greater detail. Each of the circuit breaker indicator lights will show a greater level of detail of the status of the Messenger associated with that breaker.

Figure 9.8
System Health Summary

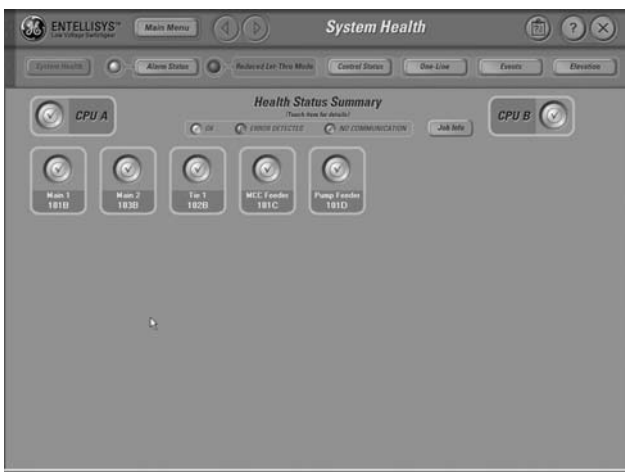

Entellisys Low-Voltage Switchgear

Section 10. Digital I/O

Digital Input/Output (Digital I/O) is an optional feature that allows Entellisys to communicate with traditional hardwired controls and monitoring. Digital I/O can be used for such situations as remote control of the circuit breakers, remote inputs to a Custom Control scheme, output of any status function in the Entellisys system (e.g., breaker status, protective relay status, and system status), or from a Custom Control scheme to a remote monitoring or control system. Digital I/O uses the Entellisys system’s Flex Logic to assign functions to the inputs and outputs.

Digital I/O is available with up to 128 configurable points, and each CPU is capable of accepting two 64-point I/O cards. Digital I/O points are configured as inputs or outputs in groups of 16 (16, 32, 48, ..., 128) through screens on the HMI.

Table 10.1 lists the Flex Logic elements that can be provided as outputs through Digital I/O.

Digital I/O is available in nonredundant and redundant configurations. Nonredundant Digital I/O communicates with only one CPU and may be used where there are simple outputs to remote monitoring systems (e.g., outputs to simulate breaker auxiliary contacts for remote indication of breaker open or closed status).

Communication with more complex external monitoring and control systems can use Ethernet or redundant Digital I/O. Redundant Digital I/O shares information with both Entellisys CPUs. Inputs are passed digitally to both CPUs so that control logic within Entellisys operates with identical information. Output redundancy is implemented as a logical-OR of the information from each CPU to each digital output.

From a hardware standpoint, Digital I/O is implemented with relay blocks, each holding up to 16 I/O points and dedicated to either 16 input or 16 output points. Typical configurations of 64 I/O points are shown in Table 10.2. Similar logic applies for 128 I/O-point capability.

External connections to the I/O points (relay blocks) accommodate single- or multiple-conductor cables made of #14 to #22 AWG wire. External (customer) connections to the I/O points are made in the I/O cubicle located in the front of the switchgear.

Inputs to the I/O points can be dry contacts, DC signals (3–32v), or AC signals (120v). When dry contacts are used as inputs, a wetting voltage of 120v AC is supplied from the switchgear control power supply.

Outputs from the I/O points are dry contacts suitable for use in AC (120v max.) or DC (100v max.) control or monitoring circuits. Each output module contact

Table 10.1
Flex Logic Outputs through Digital I/O

Breaker	Protective Relay (UV/OV/UF/OF/ PH-L/REVPWR)	Overcurrent Function (LT / ST / INST / GF)	High-Current Alarm, High-Resistance Ground (HRG)	Bus-Differential, Multisource Ground Fault	Sync Check
Opened	Alarm in pickup (timing)	LT, ST, GF in pickup (timing)	High-Current Alarm in pickup (timing)	Bus-Differential trip operated	Sources available
Closed	Alarm operated	LT, ST, INST, GF operated	High-Current Alarm operated	Multisource GF trip operated	Sources not available
Locked Out	Alarm dropped out	LT, ST, INST, GF dropped out	High-Current Alarm dropped out		Sources synchronized
Closing Spring Charged	Trip value in pickup (timing)		HRG in pickup (timing)		Sources not synchronized
Breaker in CONNECT position	Trip operated		HRG operated		
Breaker in TEST/DISC position	Trip dropped out		HRG dropped out		
Secondary Disconnect Engaged					

Table 10.2
Digital I/O Configuration

<table border="1"> <thead> <tr> <th>Input Points</th> <th>Output Points</th> </tr> </thead> <tbody> <tr><td>0</td><td>16, 32, 48, 64</td></tr> <tr><td>16</td><td>0, 16, 32, 48</td></tr> <tr><td>32</td><td>0, 16, 32</td></tr> <tr><td>48</td><td>0, 16</td></tr> <tr><td>64</td><td>0</td></tr> </tbody> </table>	Input Points	Output Points	0	16, 32, 48, 64	16	0, 16, 32, 48	32	0, 16, 32	48	0, 16	64	0	OR	<table border="1"> <thead> <tr> <th>Output Points</th> <th>Input Points</th> </tr> </thead> <tbody> <tr><td>0</td><td>16, 32, 48, 64</td></tr> <tr><td>16</td><td>0, 16, 32, 48</td></tr> <tr><td>32</td><td>0, 16, 32</td></tr> <tr><td>48</td><td>0, 16</td></tr> <tr><td>64</td><td>0</td></tr> </tbody> </table>	Output Points	Input Points	0	16, 32, 48, 64	16	0, 16, 32, 48	32	0, 16, 32	48	0, 16	64	0	=	<table border="1"> <thead> <tr> <th>Total I/O Point Capability</th> </tr> </thead> <tbody> <tr> <td>64</td> </tr> </tbody> </table>	Total I/O Point Capability	64
Input Points	Output Points																													
0	16, 32, 48, 64																													
16	0, 16, 32, 48																													
32	0, 16, 32																													
48	0, 16																													
64	0																													
Output Points	Input Points																													
0	16, 32, 48, 64																													
16	0, 16, 32, 48																													
32	0, 16, 32																													
48	0, 16																													
64	0																													
Total I/O Point Capability																														
64																														

is individually fused at 5A. Contact ratings for the output modules are listed in Table 10.3. Control circuits operating at voltages and currents exceeding the ratings of the I/O modules require interposing relays.

Each input and output module has a status LED to indicate the presence of an input signal (high) and the status of the output (ON). Operation of Digital I/O is based on positive logic.

Figure 10.1 shows the redundant Digital I/O configuration. The logical OR module is not provided with nonredundant Digital I/O, and only CPU-A is connected to the I/O modules.

Digital inputs and outputs communicate with the Flex Logic that runs on the CPUs. Flex Logic always operates in a redundant mode on both CPUs and identical Flex Logic programs run on both CPUs. When nonredundant Digital I/O is used, the inputs and outputs are connected only to CPU-A. Although both CPU-A and CPU-B run the same Flex Logic programs, only CPU-A can control the nonredundant Digital I/O.

Table 10.3
Digital I/O output module contact ratings

Maximum Contact Rating	10 W
Maximum Switching Current ⁽¹⁾	0.5 A
Maximum Carry Current ⁽¹⁾	1.0 A

⁽¹⁾ Inductive loads require diode suppression

If redundant Digital I/O is provided, inputs and outputs are connected to both CPU-A and CPU-B and both CPUs run the same Flex Logic programs. CPU-A is the default primary controller for Digital I/O and executes breaker commands and changes to digital output states. CPU-B is blocked from operating breakers and its digital outputs are 0. When *ORed* with the digital outputs from CPU-A, the output relay status is the same as the digital output from CPU-A. CPU-B continues to read the digital inputs and run its Flex Logic.

Should an issue develop with CPU-A, it will transfer control of Digital I/O to CPU-B. Outputs from CPU-A are then 0 and the digital output relays are controlled by CPU-B through the *OR-board*. CPU-B retains control of the Digital I/O until CPU-A returns to a healthy status, at which time CPU-A requests control and CPU-B relinquishes it to CPU-A.

An alarm indicates when a Digital I/O card has an issue on power-up. Events are listed in the Event Log for Digital I/O card failure type, which CPU is controlling the Digital I/O, and any time control of Digital I/O transfers from one CPU to the other.

Figure 10.1
Redundant Digital I/O Hardware Configuration

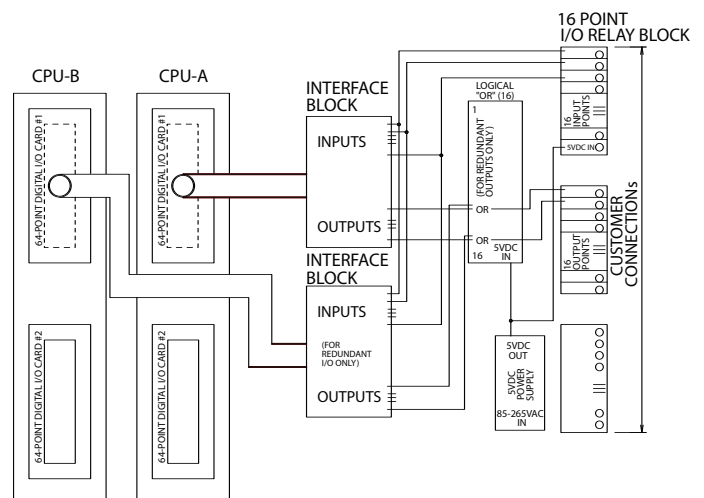

Entellisys Low-Voltage Switchgear

Section 11. Control

The control features of the Entellisys system can be implemented in several pre-engineered schemes and also in custom-engineered logic for some or all of the breakers in the switchgear lineup. The available control features include Local Control via the HMI, Bell Alarm with Lockout, Network Interlock, Automatic Transfer, Sync Check, Load Shedding, Selector Switch (Manual Transfer), Remote Control, Custom Control, and Digital Input/Output. Each of these features is described below.

Local Control

Local Control is initiated via the HMI (human-machine interface) located in the switchgear lineup, an HMI located in a separate cabinet close to the switchgear (Near-Gear HMI), or a network-connected PC with remote HMI software. Local Control can be used to open and close the circuit breakers in the lineup. Manually operated breakers can only be tripped by Local Control, while electrically operated breakers can be closed, tripped, and opened. Local control is supervised by Bell Alarm with Lockout and Network Interlock features.

Bell Alarm with Lockout

Bell Alarm with Lockout is an optional mechanical interlock mounted on the circuit breaker that prevents reclosing the breaker until the device is manually reset. Any control scheme that attempts to close the breaker before the Bell Alarm with Lockout is reset results in a failure to close. The Bell Alarm with Lockout is operated by the CPU for any system-initiated trip (not a local open operation). The Bell Alarm with Lockout is always operated by an overcurrent trip (overload, short circuit, ground fault) and can be selected to operate for any or all of the protective-relay trips (under- or overvoltage, phase loss, under- or overfrequency, power reversal). A local trip initiated from the HMI can also be selected to lock out the breaker. The Bell Alarm with Lockout must be manually reset at the circuit breaker with the yellow target button on the breaker escutcheon.

Network Interlock

Network Interlock is an optional mechanical interlock mounted on the circuit breaker. It is always supplied with the Hidden Close option for the mechanical close button on the breaker escutcheon. The Network Interlock is mutually exclusive with the Bell Alarm with Lockout (either the Bell Alarm with Lockout or Network Interlock can be supplied

but not both) and it has two states, LOCKOUT and RESET. The Network Interlock is locked out and reset via the system control logic.

Setting the Network Interlock to LOCKOUT when the breaker is closed causes the breaker to trip. In the LOCKOUT position, the Network Interlock holds the breaker mechanically trip free and also inhibits electrical closing. The control logic must provide a command to reset the Network Interlock before the breaker can be closed manually or by control logic. Loss of control power does not cause the Network Interlock to reset.

Automatic Transfer

Automatic Transfer includes a library of pre-engineered control logic for automatic transfer schemes used in double-ended (main-tie-main) lineups (three-breaker transfer). The library of automatic transfer schemes includes typical delayed-transfer and manual return-to-normal with open transition (break-before-make) and more-complex schemes of automatic transfer and automatic return with momentary paralleling (make-before-break) and synchronism check.

Sync Check

Sync Check is an optional control element that checks for synchronism between two voltage sources (adjustable voltage, angle, and frequency) and can serve as a permissive element in the control logic to allow a circuit breaker to close only when two voltage sources are synchronized. The Sync Check function includes Live/Dead Bus-Live/Dead Line sensing for bypassing the Sync Check requirement if one or both of the sources are de-energized.

Selector Switch (Manual Transfer)

Selector Switch (Manual Transfer) provides a manually initiated transfer of loads from one source to another via Flex Logic. This optional control scheme permits transfer of loads from one bus to another through either momentary parallel operation or by blocking any parallel operation. This control option also retransfers the load back to the normal source. The Selector Switch control scheme can be set for Open Transition (break-before-make) or Closed Transition (make-before-break). In the Open Transition mode, the control logic blocks any parallel operation. Transfer of loads occurs by opening one main breaker and then closing the tie breaker. Return to normal requires the tie breaker to

be opened before the main breaker can be re-closed. The three Closed Transition settings for Selector Switch are “Both Mains Closed with Tie Open,” “Main 1 & Tie Closed with Main 2 Open,” and “Main 2 & Tie Closed with Main 1 Open”. Setting Selector Switch to any of these positions causes the control logic to check for proper system conditions, enable momentary parallel operation and then open the appropriate breaker to achieve the selected configuration. The Closed Transition manual transfer is initiated by manually closing the third breaker via the Breaker Control screen.

open or closed status). Redundant I/O may be used for communicating with more-complex external monitoring and control systems and when interfaces through communicating devices are not possible.

Remote Control

Remote Control allows you to issue open commands (and close commands if the breaker is electrically operated) from a remote location using traditional hardwired control methods. The remote signals are processed through Digital I/O (see below) and the breakers are operated through the CPU.

Custom Control

Custom Control uses Flex Logic to allow factory engineers to design customer-defined control schemes for the circuit breakers. Elements used in the Flex Logic control schemes include all breaker status conditions (open, closed, locked out, racked in or out, springs charged), protective-relay pickup and delay settings, overcurrent pickup and delay settings, line-up relays (Sync Check, Multi-Source Ground Fault, Bus Differential, High Resistance Ground Fault) pickup and delay settings, alarms, and events. External inputs and outputs for Custom Control are provided by Digital I/O.

Digital Input/Output (Digital I/O)

Digital Input/Output (Digital I/O) is an optional feature that allows Entellisys to communicate with traditional hardwired controls and monitoring. Digital I/O applications include remote control of the circuit breakers, remote inputs to a Custom Control scheme, and remote outputs of any status function in the system (e.g., breaker status, protective relay status, alarm status, and system status).

Digital I/O can be provided for up to 128 configurable points and is available in either nonredundant or redundant configurations. Nonredundant digital I/O communicates with only one CPU and may be used with simple outputs to remote monitoring systems (for example, outputs to simulate breaker auxiliary contacts for remote indication of breaker

Entellisys Low-Voltage Switchgear

Section 12. EntelliGuard Preventative Maintenance

Entellisys tracks the data needed to manage preventative maintenance items. Circuit breaker transition counters, life calculations, run hours of operation, and last-operation date stamping all aid in maintaining and servicing the Entellisys system. In addition, transition counters can trigger alarms after a certain number of transitions have occurred.

The Entellisys system provides up-to-the-minute status for every circuit breaker in your Entellisys installation. There is no need to run around with a clipboard, recording the operations counter reading on each of your circuit breakers. The Entellisys system not only tracks the number of operations of each circuit breaker, but also estimates actual current breaking life and mechanical life. Entellisys shows you what you need to know, whenever you want to know it.

Viewing and Understanding the Preventative Maintenance Data

Figure 12.1 shows the Maintenance Data display that is obtained by selecting a circuit breaker from the one-line drawing. Each of these entries is described in the following.

Total Operations

Entellisys counts the number of closed-to-open transitions, regardless of load, of each EntelliGuard circuit breaker.

Total No-Load Operations

Entellisys counts the number of closed-to-open

transitions that occur with no load (less than 1% of rated current) for each EntelliGuard circuit breaker.

Total Load Operations

Entellisys counts the number of closed-to-open transitions that occur with load (1% or more of rated current) for each EntelliGuard circuit breaker.

Total Fault Operations

Entellisys counts the number of closed-to-open transitions that occur due to a fault on each EntelliGuard circuit breaker. These are trips issued by a protection feature, such as short-time, long-time, and instantaneous overcurrent.

Percent Load Life

Entellisys tracks the percentage of the total load life of the EntelliGuard circuit breaker that has been used. When an EntelliGuard circuit breaker transitions from closed to open, the percentage of load life used is updated with the equation below, which includes the frame size and the current flowing through the breaker at the time of transition. The constant K depends on the circuit breaker's frame size, as listed in Table 12.1.

$$\% \text{ of Load Life} = \sum ((I_{\text{rms}}/I_{\text{frame}})^2 / K_{\text{frame}})$$

If the current flowing through the circuit breaker at the time of transition exceeds the maximum current threshold (see Table 12.2), 45% of the breaker's life is added to the total load life used.

Figure 12.1
Breaker Maintenance Data Display

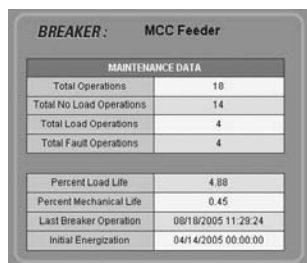

MAINTENANCE DATA	
Total Operations	18
Total No Load Operations	14
Total Load Operations	4
Total Fault Operations	4
Percent Load Life	4.88
Percent Mechanical Life	0.45
Last Breaker Operation	08/18/2005 11:28:24
Initial Energization	04/14/2005 00:00:00

Table 12.1
Frame-Size Constant Used in Calculating Percentage of Load Life

Frame Size, A	K_{frame}
800	2800
1600	1200
2000	1000
3200	600
4000	500
5000	400

Table 12.2
Maximum Current Threshold

Frame Size, A	Max current threshold
800	15
1600	15
2000	15
3200	13
4000	9
5000	7

Percent Mechanical Life

Entellisys updates the fraction of mechanical life used on each EntelliGuard circuit breaker every time the breaker transitions from closed to open. It is calculated by dividing the total number of operations by the number of rated operations, as listed in Table 12.3.

Last Breaker Operation

Entellisys records the date and time of the last operation, either closed to open or open to closed, for each EntelliGuard circuit breaker.

Adjusting the Preventative Maintenance Values

All the values described above, except for accumulated service hours and percentage total load life (which are purely calculated values) can be adjusted. Select Preventative Maintenance from the HMI User Settings menu to display the window shown in Figure 12.2. The setup tab on this screen displays the current values and lets you change the selectable fields. When a component of the Entellisys system is commissioned, replaced, or moved, adjustments must be made to all these values.

You can set thresholds on certain values to generate an alarm and send an email notification when the threshold is exceeded. These are set on the Alarms Setup screen, which is displayed by pressing the Alarms Setup button.

Notification Thresholds

Enter values in these boxes to set threshold alarms for each of the operations counters. When the count equals the threshold value, a notification email is sent according to the configuration on the Alarms Setup screen.

Table 12.3
Number of Rated Operations for Each Frame Size

Frame Size, A	Mechanical endurance
800	9700
1600	3200
2000	3200
3200	1100
4000	1100
5000	1100

Hours of Operation

Entellisys records the date and time that a circuit breaker was initially energized and displays the number of hours that have elapsed since then. These hours are a purely calculated value and are as accurate as the current system time. The equation used to calculate this is:

$${}^T\text{RunHours} = {}^T\text{CurrentTime} - {}^T\text{initialEnergizing}$$

Alerts

Alerts are automatically activated based on preventative maintenance data. The three different types of alerts, described below, can be modified through the alarm functions. Refer to Section 9 for more on alarms.

Accumulated Service Hours Alerts

Entellisys keeps track of the date and time each EntelliGuard breaker was initially energized. This value is entered into the HMI on the PM settings screen. On every anniversary of the energizing date, an alarm is activated and an event is entered in the event log.

Load Life Operation Alerts

Entellisys activates a user-defined alarm and logs an event when any EntelliGuard circuit breaker has reached 50%, 75%, or 90% of its load life operations.

Mechanical Life Operation Alerts

Entellisys activates a user-defined alarm and logs an event when any EntelliGuard circuit breaker has reached 12.5%, 25%, 37.5%, 50%, 62.5%, 75%, 87.5%, or 100% of its mechanical life.

Figure 12.2
Preventative Maintenance Display

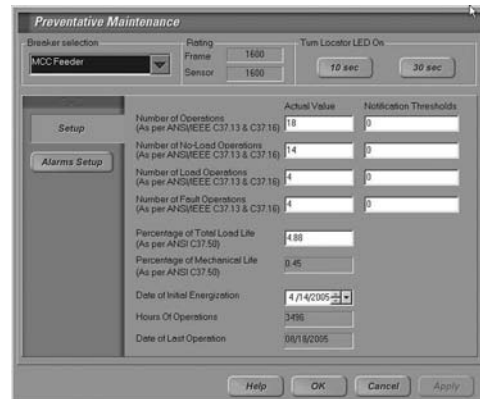

Entellisys Low-Voltage Switchgear

Section 13. User Interface – HMI

The touchscreen Human-Machine Interface (HMI) is a window into the Entellisys system. All protection, monitoring, and control is performed by the central processing units (CPUs). The HMI, the user interface with the Entellisys system, translates and displays this activity. The HMI is typically placed in the switchgear lineup or nearby in a standalone stack or wall-mounted cabinet. The operator can interrogate the entire system from one location, with easy-to-navigate screens providing clear information on the power system dynamics. No longer do you have to interpret cryptic messages on small, dimly lit screens or wonder which button or combination of buttons to press to find the information you need. With the Entellisys HMI, all of the lineup information is literally at your fingertips on a large screen displaying easy-to-understand information.

The HMI interface software operates as a kiosk, meaning that this is the only software that can be operated on this hardware. This prevents someone from loading foreign software into the HMI computer that would interfere with the visibility into the Entellisys system.

The large, 15" active matrix touchscreen display (see Figure 13.1) provides effective communication with the system. Simply touching the on-screen buttons moves you from screen to screen to the information you need. The keyboard with numeric keypad located below the screen makes data entry fast and convenient. A USB port, in the lower-right corner, protected by a hinged door, provides a fast and easy way to download files via a jump drive, as an alternative to downloading information over a LAN connection.

Figure 13.1
Touchscreen Display



The first thing an operator must do is log into the system. Each user is assigned a password by the system administrator (the person at the user's facility with Entellisys system responsibility). Each password is linked to various permissions so that access to screens and authority is matched to each individual's skill set. For instance, some operators may only have view capability, while others are allowed to open and close circuit breakers, while still others have the additional ability to change protection set points. This allows everyone to have access to the information necessary for their own jobs. After an operator performs what is needed, they can log out by touching a button. Otherwise, the HMI automatically logs out a user based on the time selected by the site's system administrator (30 or 60 minutes after the last action).

Logon data are entered via the keypad on the HMI, after which the main menu appears, as illustrated in Figure 13.2, with the available options depending on the operator's access level.

- Pressing the One-Line button displays a dynamic one-line diagram of the Entellisys system. Touching a circuit breaker symbol on the one-line diagram takes you to that circuit breaker's status screen.
- Pressing the Elevation button displays a front view of the Entellisys switchgear lineup. Touching a circuit breaker escutcheon takes you to that circuit breaker's status screen.
- Pressing the Sequence of Events button displays the event log, where you can also access fault data and system-wide waveform captures.
- Pressing the System Health button displays a screen summarizing the health status of each of the Entellisys CPUs and Messengers.

Figure 13.2
Entellisys Main Menu



- Pressing the User Settings button displays a screen from which you can access protection settings, mobile metering assignments, alarm setup, discrete I/O, control settings, and preventative maintenance details and preferences.
- Pressing the Low Energy Let-through Mode button displays a screen from which you can enable or disable that mode.
- Pressing the Maintenance button displays a screen from which you can select circuit breakers and view their mechanical and electrical life values.

To provide a view into the Entellisys system, following are various screen examples that illustrate how easy it is to navigate through the system.

The One-Line diagram is a common starting point, as illustrated in Figure 13.3. This screen displays the system’s one-line diagram, with the current for each circuit breaker, the voltage for each bus, and the circuit breaker names and status (open, closed, tripped). These values are dynamic and are refreshed according to the update time between the CPU and HMI, which is typically 2–4 seconds.

Touching any of the circuit breaker symbols on the one-line displays that circuit breaker’s status screen, as illustrated in Figure 13.4.

This display provides the status of the circuit breaker, including the contact position, racking position, secondary disconnect position, electrical lockout status, closing spring status, and a summary of the types of protection that are enabled for this circuit. Current and voltage measurements are displayed and additional metering information is available by touching the appropriate buttons for the optional metering parameters.

From the circuit breaker status screen you can also access the protection settings and predictive maintenance data for this circuit. You will see later how the protection settings and maintenance data can also be accessed via the main menu, providing more than one path to the information.

Touch the Control key to display a circuit breaker control window, as illustrated in Figure 13.5. This window shows the name of the breaker with its current state (open, tripped, or closed). If you want to confirm that you are referencing the correct circuit, you can turn on the locator LED for 10 or 30 seconds. This causes the blue Locator LED on the corresponding circuit’s Messenger to blink, providing visual identification of the circuit breaker you are referencing.

Figure 13.3
Sample One-Line Diagram

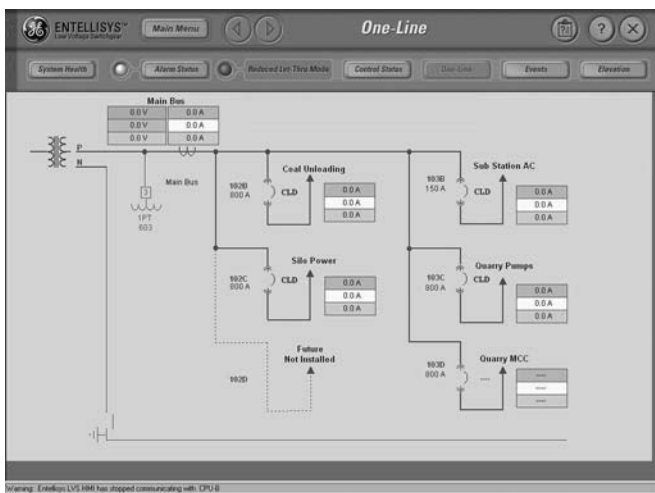
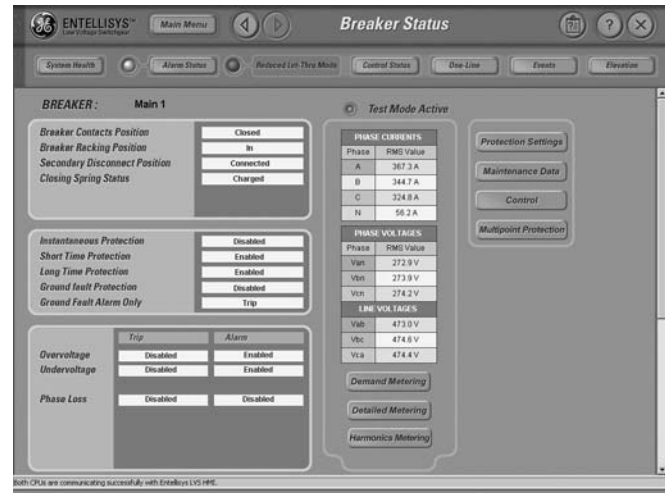

Figure 13.4
Circuit Breaker Status Display



You can operate the breaker by touching the appropriate button. Note that in Figure 13.5, Breaker 2 is “Open - Not Tripped” and the options available are to close or trip the breaker. Touching the CLOSE button displays another window asking for confirmation. After you confirm that this is what you want, the circuit breaker contacts are closed. Touching the TRIP button and again confirming this action on the corresponding pop-up window actuates the flux shifter and any lockouts associated with a trip.

In Figure 13.6, circuit breaker Main 2 is closed. Touching the OPEN button opens the circuit breaker via the shunt trip. Touching the TRIP button actuates the flux shifter and any lockout commands. In all cases, touching an Open, Trip, or Close button displays a second window asking for confirmation of the action.

A check box is available in all of the breaker control screens to block other HMIs. Checking this box prevents any other HMIs, either near-gear or remote, from operating this circuit breaker.

As illustrated, an operator can use the circuit breaker status screen to easily navigate to metering, breaker status, and protection information and also to operate the circuit breaker (with the appropriate login password). This intuitive interface is an efficient way to communicate with all the circuit

breakers. The large screen displays the information clearly and concisely. The login security levels provide operators with access to the information and control actions that are appropriate to their job functions.

Note that the header at the top of each screen, shown in Figure 13.7, contains the title of the current screen (here it is Breaker Status), with buttons to other commonly accessed screens. These function as short cuts to help you navigate without having to return to the Main Menu. The top bar includes a Main Menu button with scroll keys to the right that take you either back to the previous screen or forward to the next screen. The clipboard with question mark sends you to a screen that displays the HMI software version. The ? button displays the on-line HELP for access to navigational information. The X button closes the application, if your login ID gives you that authority.

The second row of buttons provides additional shortcuts to commonly accessed screens or a quick status indication.

- System Health provides a snapshot of the CPU and Messenger health status.
- The Alarm Status LED gives visual indication when an alarm is in pickup or has occurred and an easy way to access that information by touching the button.

Figure 13.5
Breaker Control Window for Circuit Breaker Tie 1



Figure 13.6
Breaker Control Window for Circuit Breaker Main 2



Figure 13.7
Typical Display Header



- The Reduced Let-Through LED indicates if this mode is enabled.
- The Control button displays the control panel.
- The Events button displays the Sequence of Events log.

System health, alarm status, and events are discussed in Section 9.

On the far right of the panel, the Elevation button displays the Elevation screen, as illustrated in Figure 13.8. This is a representation of the equipment in your Entellisys system. Touching any circuit breaker escutcheon displays that circuit breaker’s status screen, as discussed earlier. You can access a circuit breaker status screen from the One-Line or Elevation screen by touching the desired circuit breaker element.

The Events button opens the Sequence of Events log, as shown in Figure 13.9. The Entellisys system can capture many different types of events, providing a valuable trouble-shooting tool. A complete discussion of the Sequence of Events log is contained in Section 9. The on-site system administrator can filter the events to suit the needs of your site. This filter is accessed by pressing the Preferences button on the Events screen.

The Events log provides detailed information regarding the lineup dynamics. The times at which circuit breakers go in and out of pickup, system electronics health, and manual occurrences, such as when people log into the system, can be logged. It should be noted that the Events log can capture open and close commands issued through either the HMI or remote software. The Events log also captures when a breaker is commanded to trip by the button located on the circuit breaker escutcheon. Consequently, the Events log provides the ability to track what actually initiated a breaker opening.

Each screen shows the events for a particular day, with scrolling provided by the arrow buttons on the right side of the screen. You can scroll to different days using the arrow buttons at the bottom of the screen. You can sort events by touching the column title (date and time, source, etc.), making it easy to group or find particular events. The far-right column, titled Fault, indicates whether fault data and/or waveform data are available for the particular event.

Fault data and waveforms are accessed by touching the particular event to highlight it and then pressing the View Fault Data or Waveform buttons at the top of the log. A complete discussion of waveform capture capabilities plus examples are provided in Section 9.

Figure 13.8
Elevation Display

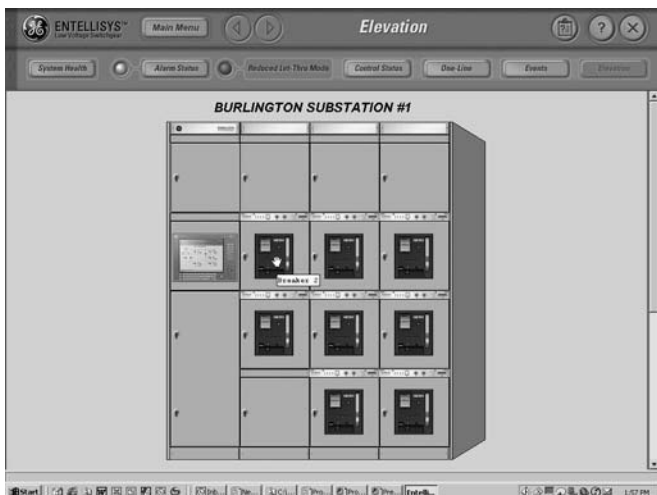

Figure 13.9
Sequence of Events Log



From any screen you can press the Main Menu button to return to the Main Menu screen. Another area that is accessible from the Main Menu is User Settings. Again, only operators with permission to access User Settings will see this button on the Main Menu. Figure 13.10 shows the User Settings screen, which displays the various settings that are available.

For instance, the Overcurrent Protection button displays the screen shown in Figure 13.11. This provides a summary of the overcurrent protection enabled for the circuit selected in the top-left corner. There are individual screens for short-time, long-time, and instantaneous settings. Figure 13.11 is an example of the screen for setting long-time protection.

Similar displays for the single-point relays (under- and overvoltage, under- and overfrequency, power reversal, and high-current alarm) are accessed by touching the Relay Protection button.

The Advanced Protection button displays the screens to set bus-differential, dynamic ZSI, and multisource ground-fault protection.

On the User Settings screen, pressing the Control button provides access to circuit breaker open, close, and trip commands; Flex Logic settings; control alarms; and Sync Check settings and status.

The Discrete I/O button displays details of all the inputs and outputs. The Preventative Maintenance button provides information on each circuit breaker’s electrical and mechanical life. Details and screens are found in Section 12.

The HMI Preferences command provides the path to alter the auto log-out time of the HMI. You can also set up near-gear and remote HMIs from the primary HMI.

Again from the Main Menu, the Low Energy Let-Thru button enables or disables this settings group. A detailed discussion of this mode is included in Section 4.

Also found on the Main Menu is User Administration, from which your site’s Entellisis system administrator assigns passwords and permissions and performs other administrative items, such as changing circuit breaker names.

While descriptions and screen captures can provide you with a basic understanding of navigation in the Entellisis system, a virtual tour of the system gives you a real sense of the power and ease of use of the Entellisis system. Your local sales representative can provide you with additional information, or log on to URL NAME at your convenience.

Figure 13.10
User Settings Display



Figure 13.11
Long-time Overcurrent Protection Setting Display

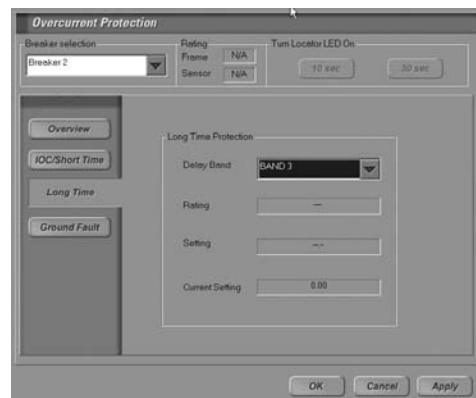

Notes

Entellisys Low-Voltage Switchgear Section 14. Remote Communication

The Entellisys system provides various ways for users to interact from remote locations, be it a few hundred feet away or across an ocean. It is vital that information be easily accessible so that users can be aware of alarm conditions, check on the system when traveling, or troubleshoot in the middle of the night when the phone rings. Of course, other information systems in the facility may need data from the switchgear, making it necessary to pass data from Entellisys to distributed control systems, power management systems, or building automation system. All of these options are available with Entellisys low-voltage switchgear.

The interface from the Entellisys system to the external world is a communication link at the system Ethernet switch (see Figure 14.1). This allows communication with the outside world without compromising the integrity of the network communication bus that is facilitating the protection and control for the system. CPU-to-Messenger communication is accomplished in a closed network to provide security and proper functioning of the network. The HMI(s) and remote connections communicate with the CPUs via the system interface Ethernet switch, keeping the outside world isolated from the protection network.

A Virtual Private Network (VPN) firewall device provides business-class network security providing denial-of-service protection and intrusion detection using Stateful Packet Inspection, URL access and content filtering, logging, reporting and real-time alerts. *It is strongly recommended that anytime an Entellisys system is connected to the intranet, a VPN firewall be installed to protect the Entellisys system from network threats.*

There are four types of remote communication options with Entellisys:

- Multiple HMIs, which consists of a primary HMI on the gear or near it and other HMI(s) located in or near the gear. *Near-gear* HMIs must be located within 300 cable feet of the primary HMI.
- Software available from GE that is loaded on a desktop or laptop computer for viewing the Entellisys system. This package is called Entellisys Remote View-Only Software.
- Software available from GE that is loaded on a desktop or laptop computer for viewing and controlling the Entellisys System. This option allows you the same permissions to change settings, close breakers, etc., as if you were at a local HMI. This package is called Entellisys Remote Interactive Software.
- If an interface to another system is required, Entellisys supports the open protocol of Modicon Modbus RTU, and is available over Ethernet via Modbus/TCP. This allows development of interface software with the Entellisys system and your external information systems.

The CPUs support a maximum of eight concurrent sessions, so they can communicate with eight different users/devices/system. Four of these sessions are reserved for HMI computers. The remaining four sessions are available on a first-come, first-served basis for remote devices, such as Entellisys remote access software or DSC or SCADA type interfaces. If a remote device does not make a request within 30 seconds, the session times out and is available to the next device that initiates a session.

Multiple HMIs

Each Entellisys system has an HMI that is designated as the primary HMI. This is the HMI connected to

Figure 14.1
Entellisys External Interface

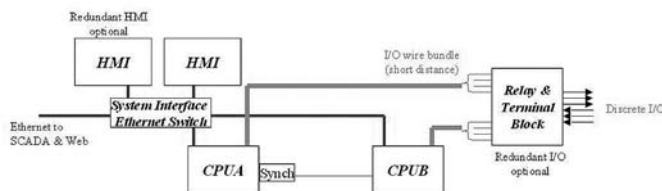

the Entellisys UPS control power system. All HMIs are capable of downloading new files, such as updated functionality or revised configurations. Each HMI also has the ability to publish HMI files to the other HMIs, provided the user has administrator authority to do so.

When operators log into an HMI, they can execute any actions that are permitted according to their user profiles. The user administrator sets up each user individually and identifies what actions they are designated to execute. This allows many operators to have access to the system based on the individual's skill level.

“Near Gear” HMIs

HMIs may be placed in a stand-alone stack or a wall-mounted box up to 300 cable feet from the system interface Ethernet switch. This gives an operator access to metering, monitoring, and diagnostic information as well as any other functions permitted by their password level. This is also an excellent method to keep operators at a distance from the actual gear.

Remote View-Only Software

Software is available that can be loaded on a laptop or desktop computer that provides the same screens

as the HMI. The computer is connected to the LAN or WAN and communicates with the Entellisys system. The View-Only software permits users to view the information and does not allow a person to change settings or control breakers, regardless of their password level.

Remote User Interactive Software

Entellisys User Interactive software also can be loaded on a laptop or desktop and provides the same images as if you were using a touchscreen HMI, only this is connected via LAN or WAN. Each user can perform any of the functions their password level allows from a remote location.

Modbus / TCP Interface

The Entellisys system supports Modbus/TCP, and the CPU always acts as a slave device, listening and responding to the requests issued by the external master computer. A subset of the Remote Terminal Unit (RTU) protocol format is supported that allows extensive monitoring, programming, and control functions using read and write register commands.

Entellisys Low-Voltage Switchgear Section 15. Design Considerations

When designing low-voltage switchgear there are a number of factors to take into account.

Repetitive duty

Circuit breakers are designed primarily to perform the function of circuit interruption under short-circuit conditions. Nevertheless, modern circuit breakers' mechanisms are capable of many operations under full-load operation and in-rush conditions such as those encountered in motor starting applications. Industry standards have been established for the minimum performance, as indicated in Table 15.1. With adequate maintenance, GE breakers can be expected to exceed the standards. EntelliGuard breakers have been designed and tested to allow the user to extend the normal maintenance service interval up to two times the ANSI recommendation — a significant benefit for continuous process and 24/7 operations.

Power-operated circuit breakers, when operating under usual service conditions, shall be capable of operating the number of times specified, and the operating conditions and the permissible effect of such operations upon the breaker are listed in Table 15.1 and the footnotes. For instance, the breaker should be operated with rated control voltage applied. The frequency of operation should not exceed 20 in 10 minutes or 30 in an hour (rectifiers or other auxiliary devices may further limit the frequency of operation). Servicing consisting of adjusting, cleaning, lubricating, tightening, etc., as

recommended by the maintenance manual, is to be done at no greater interval than shown in the column titled “Number of operations between servicing” in Table 15.1. No functional parts should require replacement during the listed operations. The circuit breaker should be in condition to carry its rated continuous current at rated maximum voltage and perform at least one opening operation at rated short-circuit current. After completion of this series of operations, functional part replacement and general servicing may be necessary.

This standard applies to all parts of a circuit breaker that function during normal operation. It does not apply to other parts that function only during infrequent abnormal circuit conditions.

Standards and testing

EntelliGuard low-voltage power circuit breakers are designed and tested to meet ANSI Standards C37.13, C37.16, C37.17 and C37.50. The breakers are listed to UL 1066 and labeled to certify compliance with the above referenced standards.

Power factors lower than test values affect the circuit breaker's short-circuit current rating. The test circuit X/R ratio and power factor required by ANSI C37.13 is 6.6 and 15% for unfused breakers and 4.9 and 20% for fused breakers. The derating factor for systems with power factors lower than test values is shown in Table 15.2.

Table 15.1

Repetitive Duty and Normal Maintenance (from ANSI C37.16 Table 5)

Circuit breaker frame size (amperes)	Number of operations between servicing	Number of operations rated continuous current switching ^{1,2,4}	Number of operations no-load closing and opening ¹	Number of operations in-rush current switching ^{3,4}
800	1750	2800	9700	1400
1600	500	800	3200	400
2000	500	800	3200	400
3200	250	400	1100	—
4000	250	400	1100	—
5000	250	400	1100	—

¹ Servicing consists of adjusting, cleaning, lubricating, tightening, etc., as recommended by the manufacturer. When current is interrupted, dressing of contacts may be required as well. The operations listed are on the basis of servicing at intervals of six months or less.

² With closing and opening currents up to the continuous current rating of the circuit breaker at voltages up to the rated maximum voltage (85% or higher power factor).

³ The number of operations was determined with closing currents up to 600% and opening currents up to 100% (80% power factor or higher) of the continuous current rating of the circuit breaker at voltages up to the rated maximum voltage. With closing and opening currents up to 600% (50% power factor or less) of the continuous current rating of the circuit breaker at voltages up to rated maximum voltage, the number of operations shown should be reduced to 10% of the number listed in the column.

⁴ If a fault operation occurs before the completion of the listed number of operations, servicing is recommended and possible functional part replacement may be necessary depending on previous accumulated duty, fault magnitude, and expected future operations.

Table 15.2

Derating Factor for Systems with Power Factors Lower than Test Values

System short-circuit power factor (%)	System X/R ratio	Derating factors for breaker short-circuit current rating	
		Unfused	Fused
20	4.90	1.000	1.000
15	6.60	1.000	0.938
12	8.27	0.966	0.902
10	9.95	0.938	0.875
8.5	11.72	0.920	0.847
7	14.25	0.902	0.826
5	20.00	0.875	0.794

Temperature derating factors

The continuous current rating of EntelliGuard breakers is based on their use in an enclosure at 40°C ambient temperature and 105°C maximum breaker temperature for Class A insulation. All Entellisys components are designed to operate at a maximum temperature of 55°C. This accounts for a 15°C rise in temperature between the exterior ambient temperature of the switchgear electrical room and the inside of the cubicles housing the Entellisys system components.

Altitude correction factors

When applying low-voltage power circuit breakers at altitudes greater than 6,600 feet, their continuous current rating must be modified because a higher temperature use will be experienced for a given current rating. The voltage ratings must also be modified because of the lower dielectric strength of the air. These are shown in Table 15.3. The short-time and short-circuit current ratings are not affected by altitude. However, the short-circuit current ratings shall not exceed that of the voltage class before derating.

Humidity

Ferrous parts are zinc-plated for corrosion protection except for some parts made from alloy steels that are inherently corrosion resistant. Current-carrying parts are silver- or tin-plated for corrosion protection and to assure electrical continuity. Heaters may be added to indoor sections operating in high humidity environments. Heaters are mounted in the bus/cable compartment in the rear of each section.

Seismic Certification

Entellisys switchgear with EntelliGuard circuit breakers has been qualified for use in moderate and high seismic loading conditions as defined in IEEE Std 693-1997. Moderate seismic loading conditions are defined by forces up to 0.25g ZPA horizontal and 0.20g ZPA vertical. High seismic loading conditions are defined by forces up to 0.50g ZPA horizontal and 0.40g ZPA vertical.

Paint Finish

Entellisys switchgear is protected by the “E-coat” paint system consisting of a “cathodic electrodeposition” process employing the same principle used in electroplating: an electrically charged object immersed in a bath of oppositely charged particles will attract, and become coated with, those particles. In the process, switchgear parts are conveyed through a seven-stage washing process, where they are thoroughly cleaned, surface prepared, sealed and rinsed. Next, the parts are immersed in an electrocoating tank, where they receive an epoxy coating 0.7 to 0.8 mil thick on every surface. After a rinse, the parts enter a curing oven, where the coating is baked, fusing it to the metal and ensuring a hard, uniform finish. The resulting ANSI-61 light gray paint finish far exceeds the requirements of UL 1558 and ANSI C37.20.1, which requires, at a minimum, passing a 200-hour salt spray test. Periodic testing by an independent laboratory subjects the “E-coat” to a minimum of 500 hours of a salt spray, 2,000 hours in a humidity cabinet, plus acid and alkaline resistance tests, spot and stain tests, marring tests and impact and flexibility tests. These tests prove that Entellisys switchgear can handle different severe operating environments.

Equipment Options

Additional items to consider when designing low-voltage switchgear are discussed below.

Control circuit isolation

In Entellisys equipment, control wires are run between compartments in steel riser channels. Customer terminal blocks are located in metal enclosed wire troughs in the rear cable area or at the barrier-mounted digital I/O relays. Intercubicle wiring is run in a wireway on top of the switchgear where interconnection terminal blocks are located.

All Entellisys communication wiring is run as “home runs” (no splices) between communicating devices. This includes the communication cables between the Messengers, network switches, and

Table 15.3
Altitude Correction Factors (as Listed in ANSI C37.13)

Altitude		Rating correction factor	
Meters	Feet	Continuous current	Voltage
2000	6600 (and below)	1.00	1.00
2600	8500	0.99	0.95
3900	13000	0.96	0.80

CPUs and between the CPUs, network switches and HMI. Communication wiring crossing shipping splits is disconnected at the network switches and pulled back to the shipping split. During installation, the communication wiring is uncoiled at the shipping split and pulled back to the section(s) with the network switches. The color-coded Cat5 cables are then plugged back in to the ports on the network switches.

Cable space

Entellisys low-voltage switchgear conduit entrance area meets NEC requirements. Extended depth frame options are available in 7” and 14” sizes for applications requiring additional cable space. Section width can also be increased (from 22” to 30” or 30” to 38”) for additional cable space.

Cable Terminations

Cables used for low-voltage power circuit breaker terminations in Entellisys low-voltage switchgear must have minimum 90°C insulation while the cables’ ampacity will be based on a 75°C rating. This meets the requirements of ANSI C37.20.1, UL1558 and the National Electrical Code. Refer to Table 15.4 for typical cable ampacities (derating factors that may apply are not shown).

Breaker Lifting Device

Installed on top of the switchgear, this rail-mounted hoist provides the means for installing and removing breakers from the equipment and is an optional feature. A floor-standing, portable hydraulic lifting device is also optionally available for installing and removing circuit breakers from the equipment.

Lifting Tool

The lifting tool is the interface between the breaker and the overhead breaker lifting device or any other portable lifting means that may be used for installing and removing the EntelliGuard drawout breakers. It attaches to the breaker to provide stability when lifting the breaker from its drawout rails. Pickup

points on the breaker and lifting tool are designed for center-of-gravity lifting so that the breaker is not subject to excess movement when removed from the cubicle.

The lifting tool for 800-2000A frame breakers features 3-point lifting for easier installation of fused and unfused breakers. Separate lifting tools are used for 3200-4000A breakers and for 5000A breakers and fuse roll-outs.

Section 16 discusses circuit breaker and Entellisys device placement and provides guidelines for the switchgear layout.

Table 15.4

Example (from NEC Table 310.16)

Cable Size	90°C rating (ref.)	75°C rating (of 90°C cable)
500kcmil	430 Amps	380 Amps
600kcmil	475 Amps	420 Amps

Notes

Entellisys Low-Voltage Switchgear Section 16. Layout and Sizing

Entellisys indoor low voltage switchgear height is 92" (97" over the top wiring trough and 103.5" over the optional breaker hoist). The available breaker stacking space is 84".

Breaker frame size and type determine the width of the breaker sections and also the minimum depth of the switchgear line-up. Refer to Tables 16.1 and 16.2 for properly sizing Entellisys line-ups. The depth of the entire line-up is determined by the deepest device in the line-up. For example, a line-up with an EGF-20 breaker with a fuse roll-out (depth – 60") and EGF-08 breakers (depth – 67") would be a minimum of 67" deep – the EGF-08 being the deepest device. Also refer to the section arrangements on the following pages for available breaker stacking configurations.

Switchgear Layout Considerations

1. Sections on the following pages can be bussed together if there are matching bus levels in the adjacent sections. Refer to the sample ENTELLISYS line-up.

2. Any breaker compartment shown on the section drawings can be made blank to provide additional space for mounting Entellisys devices. See Tables 16.5 and 16.6 for device and cubicle data.
3. The ampere ratings shown beside each breaker symbol indicate the range of frame sizes that are allowed in the particular section arrangement. This takes into consideration the temperature rise in the section due to breaker loading. Refer to ANSI C37.20.1-2002 para 8.4.2.3 for cumulative circuit breaker loading guidelines.
4. Devices cannot be mounted on breaker cubicle doors.
5. 3200A, 4000A, and 5000A fuse roll-outs are the same size as their respective breakers, therefore any compartment shown with a 3200, 4000, or 5000 amp breaker will also accommodate a fuse roll-out and vice versa.
6. Front busway connections to a circuit breaker require a blank compartment above the breaker for busway above or a blank compartment below the breaker for busway below.

Table 16.1
Indoor Enclosure Depth Options

	Available Depth Options					
Front compartment	30"			37"		
Rear compartment (Std depth or 7" or 14" rear extension)	30" (std)	37" (7" ext)	44" (14" ext)	30" (std)	37" (7" ext)	44" (14" ext)
Total depth	60"	67"	74"	67"	74"	81"

Table 16.2
Entellisys Switchgear Section Sizing

Breaker Type	Device Combination or Bus Rating	Frame Size (Amperes)	Breaker Cubicle Vertical Height (Inches)	Minimum Section Width ³ (Inches)	Minimum Equipment Depth [Front/Rear Compt] (Inches)	Optional Equipment Depth (Inches)
EGS-08		800	21	22	60 [30 /30]	67/74
EGH-08					67 [37 /30]	74/81**
EGX-08					60 [30 /30]	67/74
EGF-08					67 [37 /30]	74/81**
EGS-16		1600	21	22	60 [30 /30]	67/74
EGH-16					60 [30 /30]	67/74
EGF-16					67 [37 /30]	74/81**
EGS-20					60 [30 /30]	67/74
	EGF-20 with fuse roll-out	2000	56	30	60 [30 /30]	67/74/81 ²
EGS-32		3200	35	30	60 [30 /30]	67/74/81 ²
EGH-32					60 [30 /30]	67/74/81 ²
EGX-32					60 [30 /30]	67/74/81 ²
					EGF-32 with fuse roll-out	84
EGS-40		4000	35	30	60 [30 /30]	67/74/81 ²
EGH-40					60 [30 /30]	67/74/81 ²
EGX-40					60 [30 /30]	67/74/81 ²
					EGF-40 with fuse roll-out	84
EGS-50		5000	35	38	74 [37 /37]	81**
EGH-50					74 [37 /37]	81**
EGX-50					74 [37 /37]	81**
					EGF-50 with fuse roll-out ¹	74 [37 /37]
	1600-4000A main bus rating	—	—	—	60 [30 /30]	67/74/81 ²
	5000A main bus rating	—	—	—	67 [30 /37]	74/81 ²

¹ Breaker and fuse roll-out must be mounted in separate vertical sections.

² 81" depth available only when these devices are used in a line-up with items identified with **.

³ Section width can be increased for additional cable / conduit space. 22" sections can be increased to 30" wide, 30" wide sections can be increased to 38" wide.

7. Use of fused breakers does not necessarily require 200kA bus bracing. Bus bracing should be based on the available short circuit current on the switchgear bus.
8. 200kA bus bracing can limit feeder breaker placement. 200kA bus bracing does not allow adjacent 22 inch wide sections.
9. Factory review of layout is required for bus bracing greater than 100kA
10. Some cable entrance designs are not suitable for service entrance. Consult the factory if service entrance is required for the incoming cable section.
11. Additional cable and conduit space is available by making breaker sections wider (22 inch wide

to 30 inch wide or 30 inch wide to 38 inch wide) or by making the line-up deeper (7 or 14 inches). Refer to Table 16.2 for switchgear depth options.

Special Considerations for 5000 Amp Equipment

1. Minimum depth of a 5000A breaker section is 74 inches.
2. Upper and lower bus levels are available at 5000 amps. The center bus level is not available at 5000 amps.
3. 5000 amp bus is available as a bare bus design or with bus compartment barriers.
4. Sections adjacent to a 5000 amp transformer transition section must be 30 inches wide, minimum.

Table 16.3

Switchgear Weights

Procedure:

A) Add the weight of every vertical section in the lineup

B) Add the weight of each breaker and fuse roll-out in the lineup

Section Width	Number of Breaker Compartments ¹ in Vertical Section	Vertical Section Weights, Lb. (Kg)
22"	1	940 (426)
	2	1100 (499)
	3	1270 (576)
	4	1440 (653)
30"	1	1300 (590)
	2	1400 (635)
38"	1	1660 (753)
	2	1900 (862)
22" or 30"	Auxiliary section	1170 (531)

¹ Also includes number of fuse roll-outs in the vertical section.

Table 16.4

EntelliGuard Breaker and Fuse Roll-out Weights, Lbs. (Kg)

Device	Manual	Electrical
EGS / EGH-08	188 (86)	193 (88)
EGX-08	198 (90)	203 (92)
EGF-08	233 (106)	238 (108)
EGS / EGH-16	198 (90)	203 (92)
EGF-16	243 (111)	248 (113)
EGS-20	203 (92)	208 (95)
EGS / EGH / EGX-32	455 (207)	470 (214)
EGS / EGX-40	560 (255)	575 (261)
EGS / EGX-50	600 (273)	615 (280)
2000/3200A fuse roll-out (EG32FRE)	330 (150)	3 fuses – add 75 (34)
4000A fuse roll-out (EG40FRE)	335 (152)	3 fuses – add 90 (41)
5000A fuse roll-out (EG50FRE)	345 (156)	3 fuses – add 90 (41)

Entellisy Sample Layout

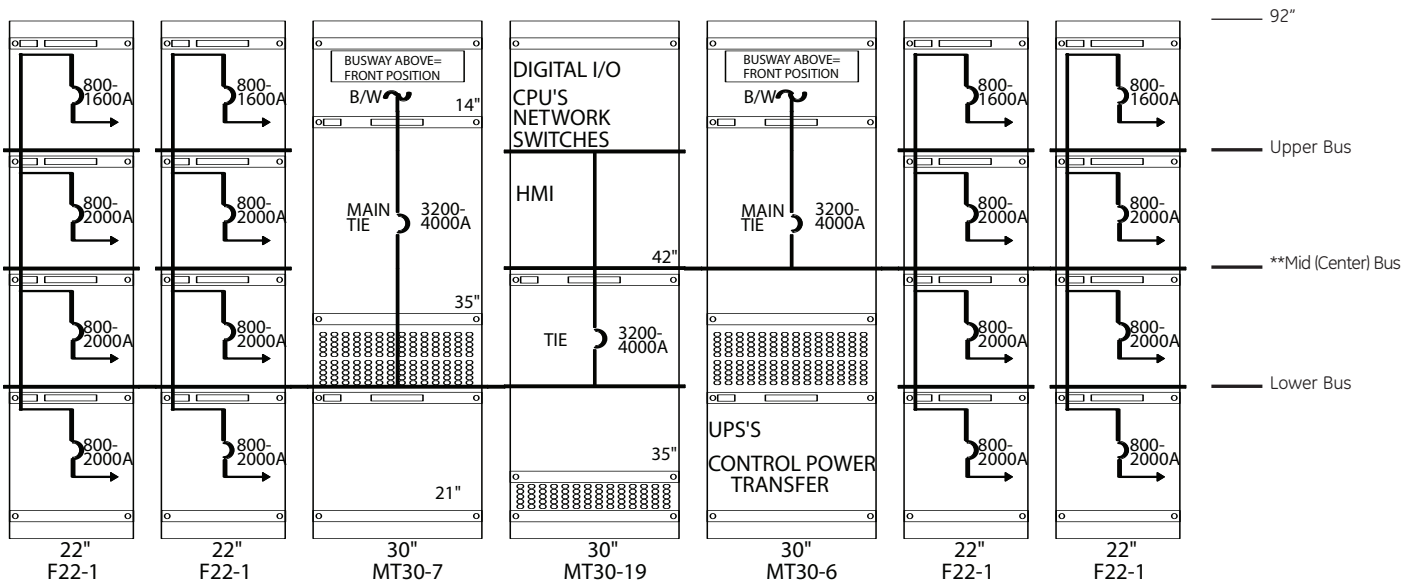

Entellisys 22" Sections (Main, Tie, Feeder)

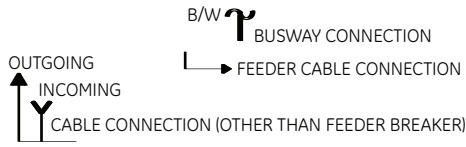

** MID (CENTER) BUS LEVEL IS NOT AVAILABLE AT 5000A (USE ONLY UPPER OR LOWER BUS LEVELS)

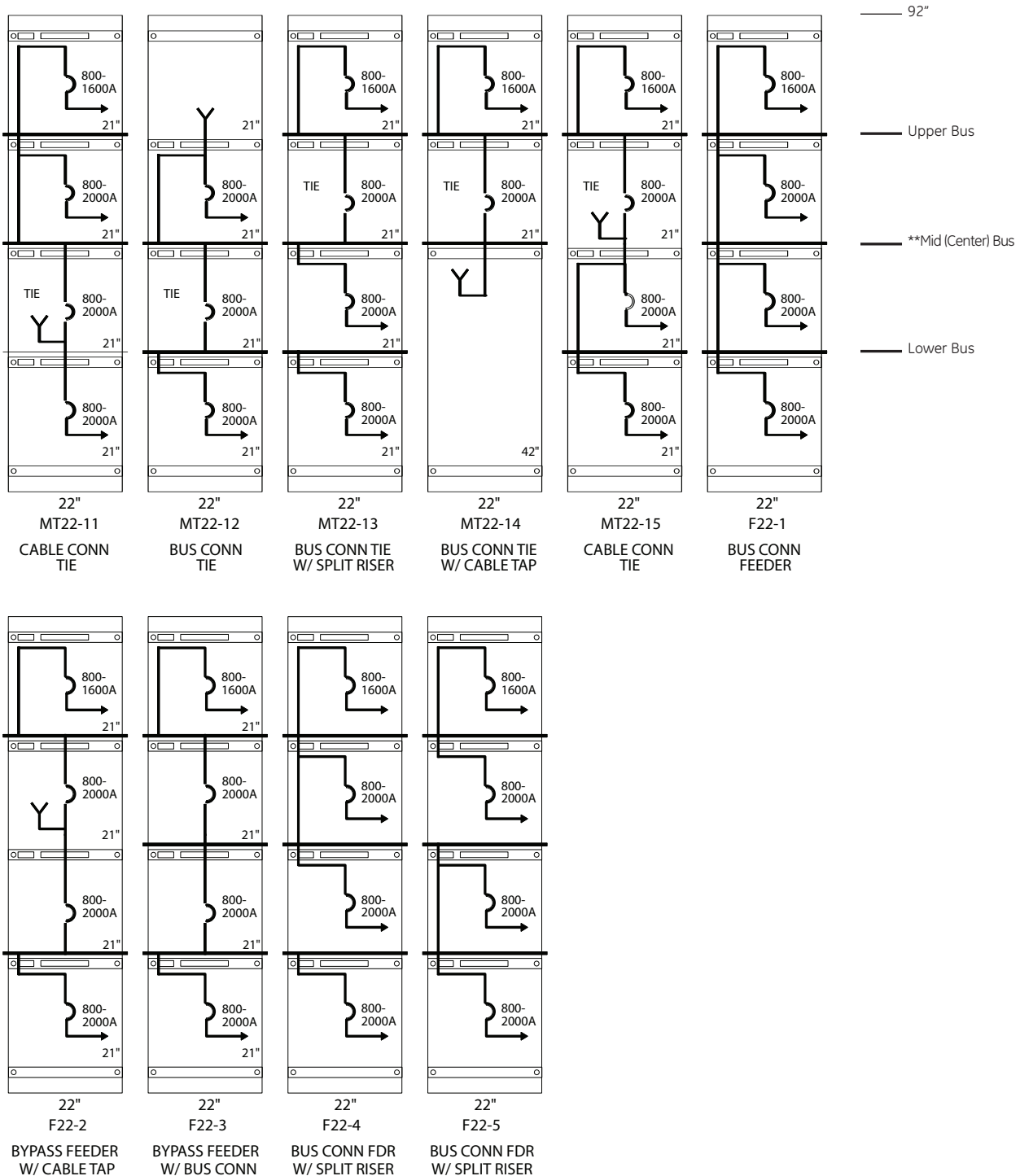

Entellisys 22" Sections (Feeder, Transformer Transition)

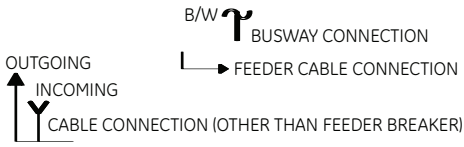

** MID (CENTER) BUS LEVEL IS NOT AVAILABLE AT 5000A (USE ONLY UPPER OR LOWER BUS LEVELS)

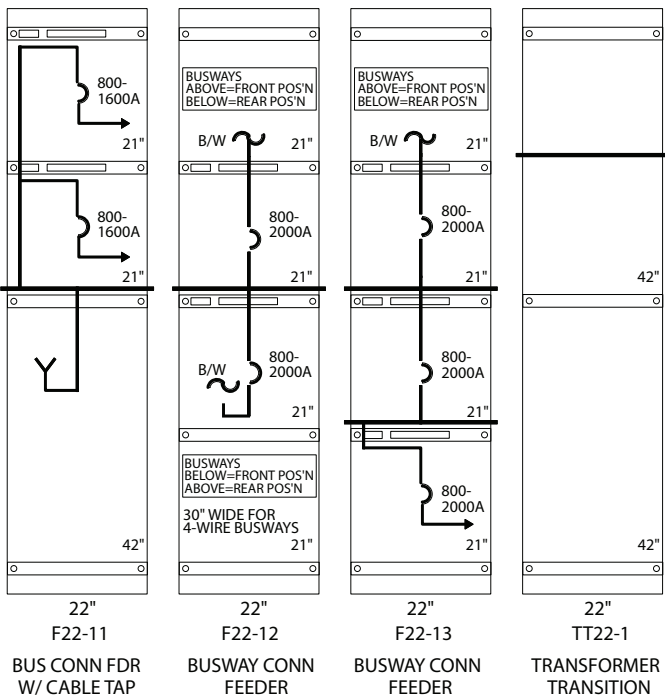
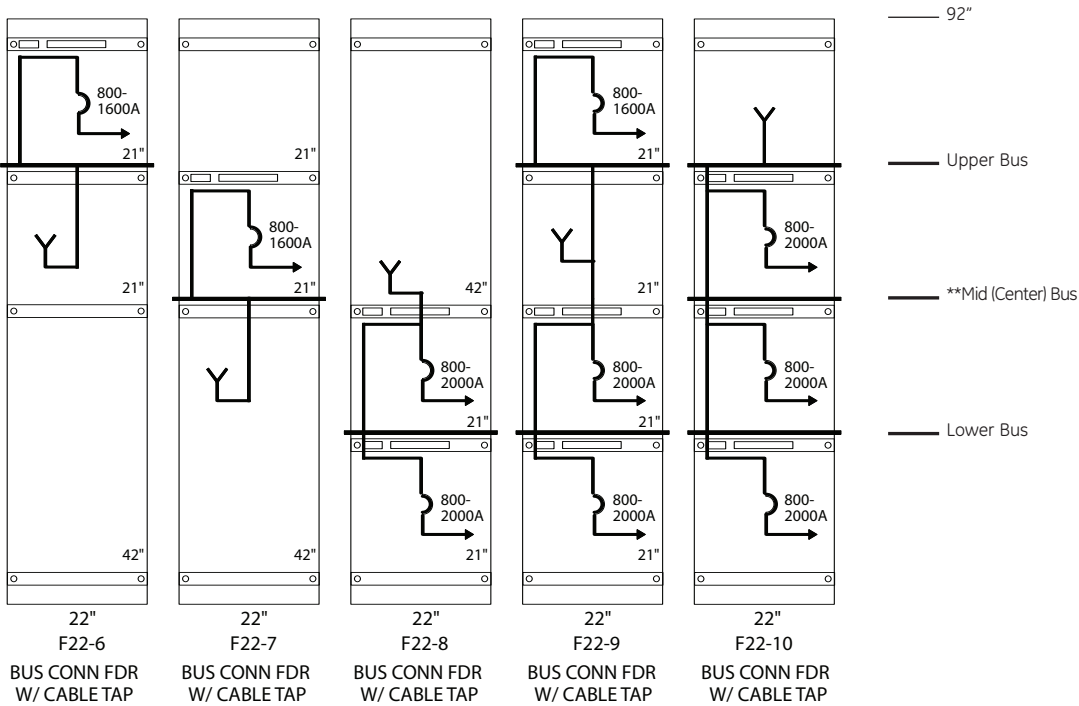

Entellisys 22"/30" (Auxiliary) and 30" Sections (Main, Tie)

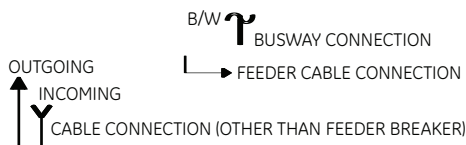

** MID (CENTER) BUS LEVEL IS NOT AVAILABLE AT 5000A (USE ONLY UPPER OR LOWER BUS LEVELS)

22"/30" Sections

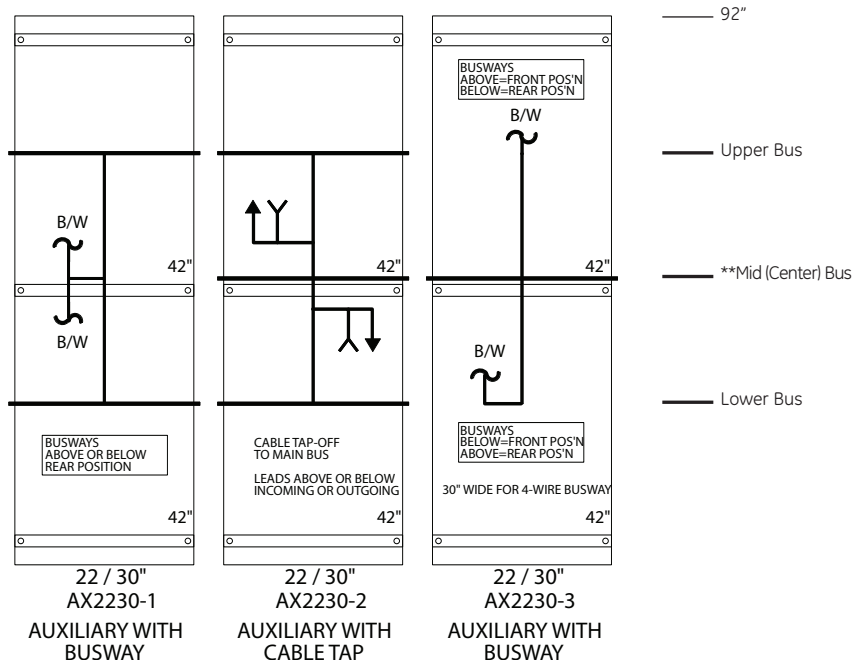

30" Sections

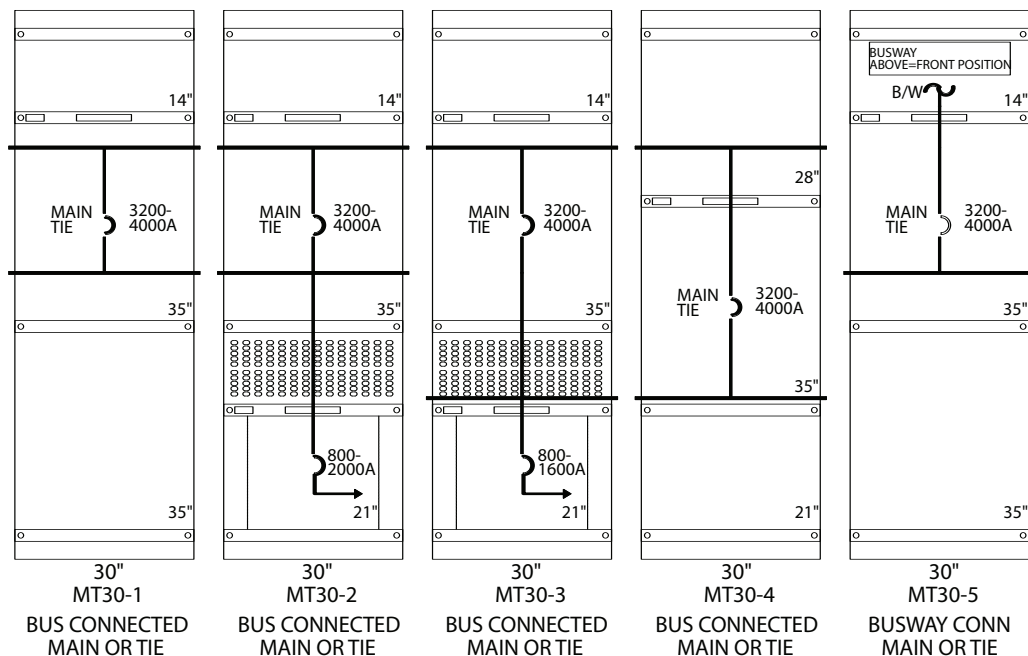

Entellisy 30" Sections (Main, Tie)

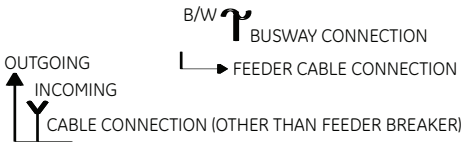

** MID (CENTER) BUS LEVEL IS NOT AVAILABLE AT 5000A (USE ONLY UPPER OR LOWER BUS LEVELS)

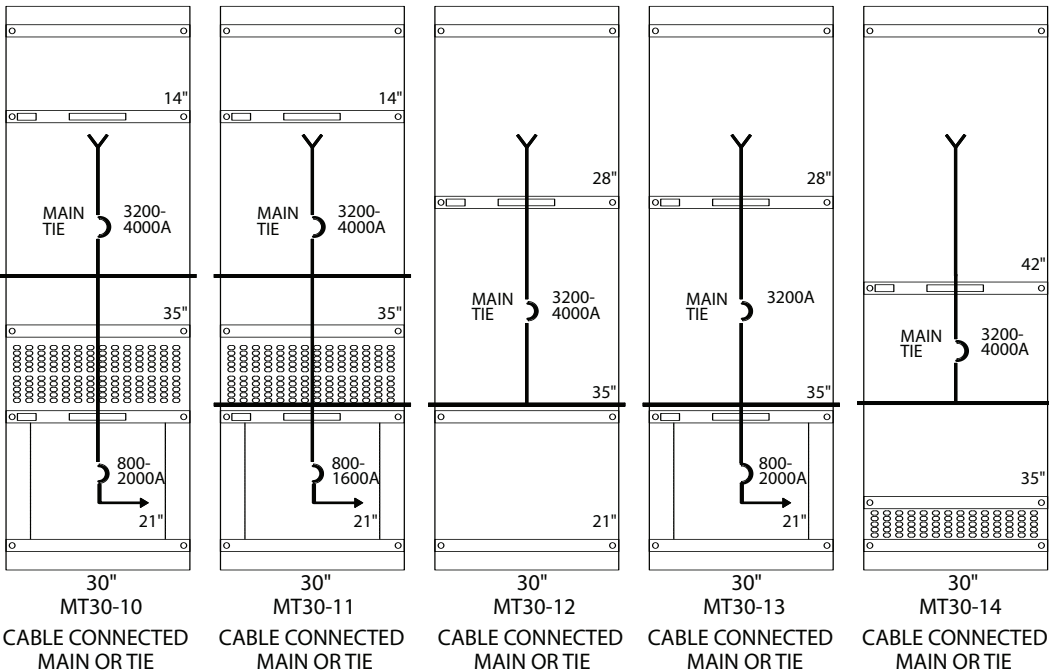
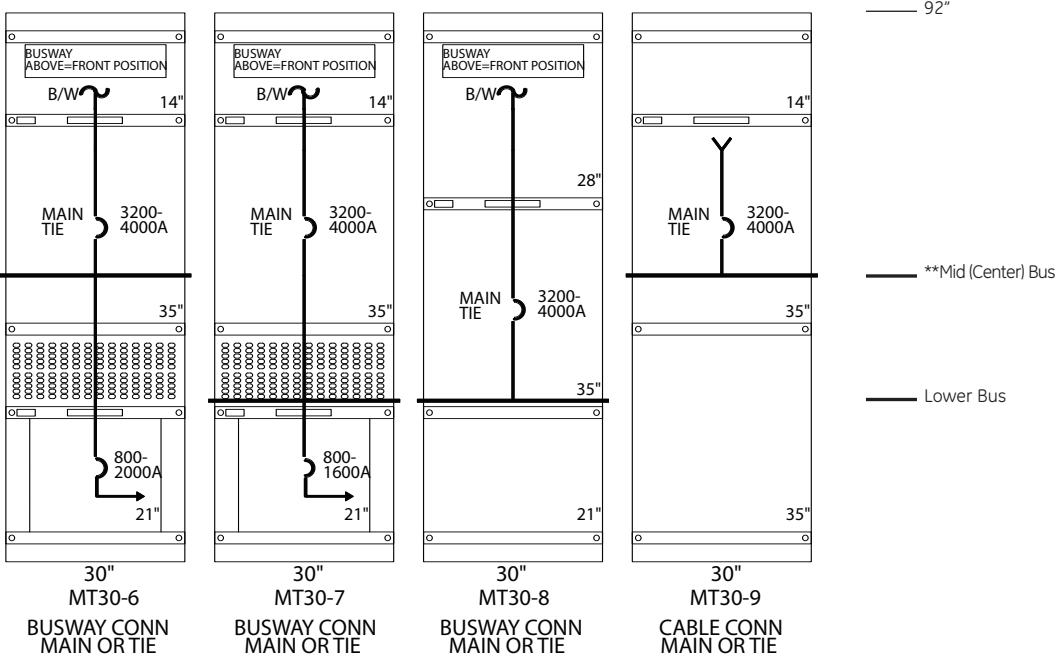

Entellisys 30" Sections (Main, Tie)

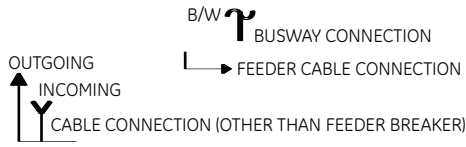

** MID (CENTER) BUS LEVEL IS NOT AVAILABLE AT 5000A (USE ONLY UPPER OR LOWER BUS LEVELS)

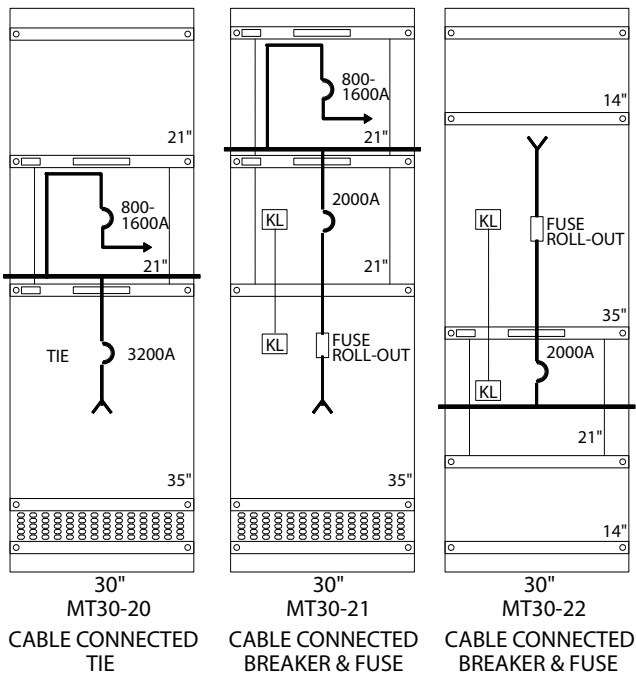
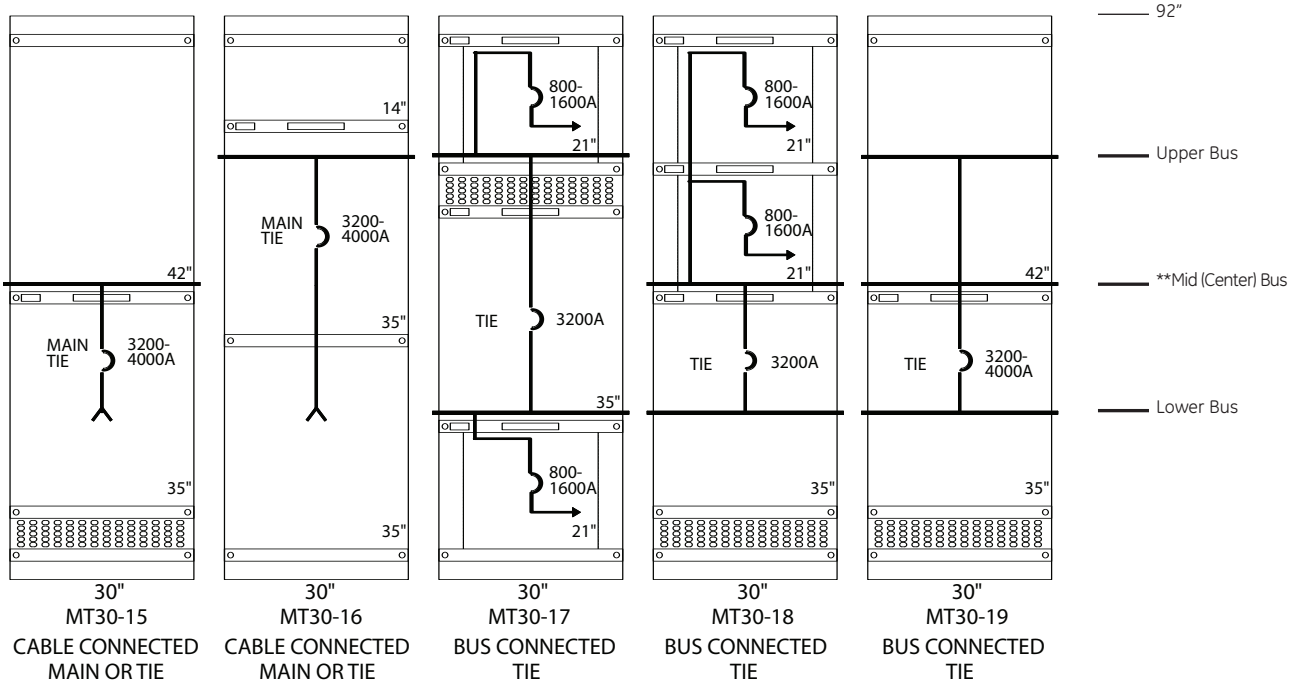

Entellisys 30" Sections (Feeder)

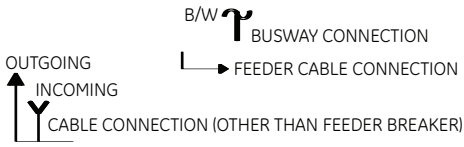

** MID (CENTER) BUS LEVEL IS NOT AVAILABLE AT 5000A (USE ONLY UPPER OR LOWER BUS LEVELS)

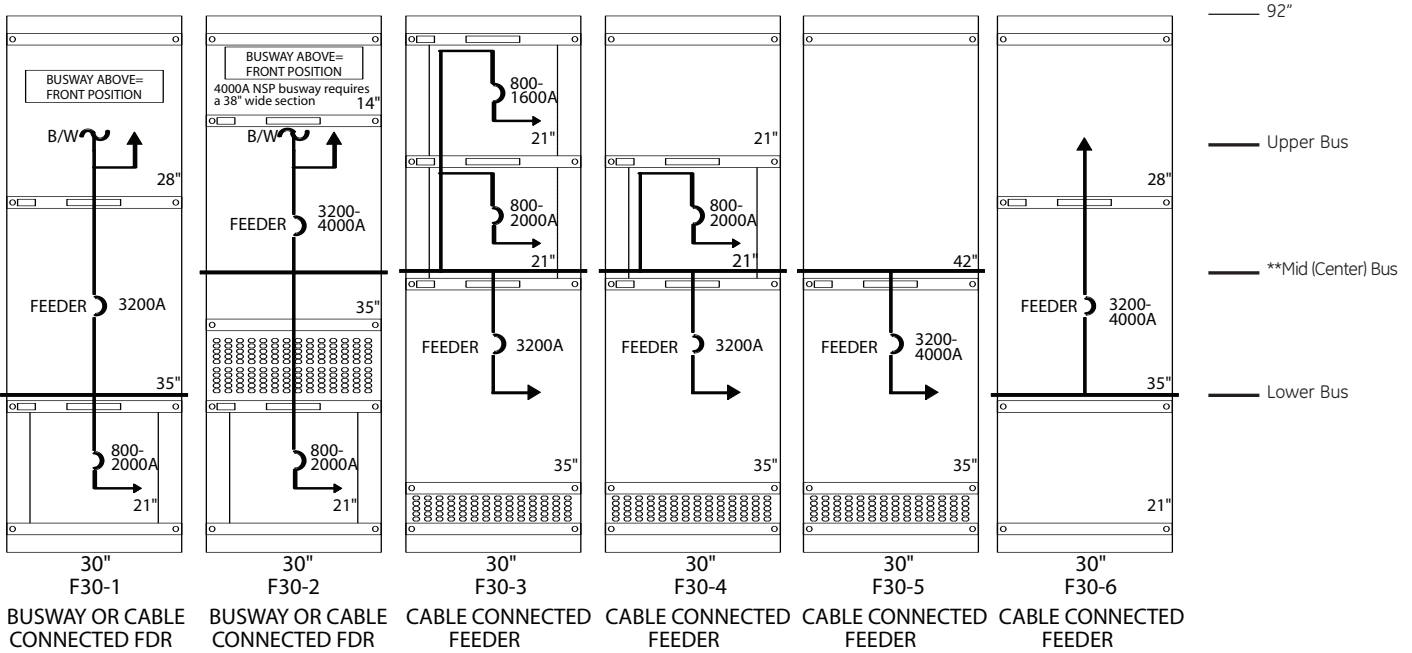

Entellisys 38" Sections (Main, Tie)

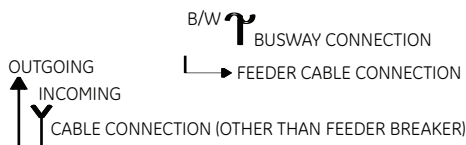

** MID (CENTER) BUS LEVEL IS NOT AVAILABLE AT 5000A (USE ONLY UPPER OR LOWER BUS LEVELS)

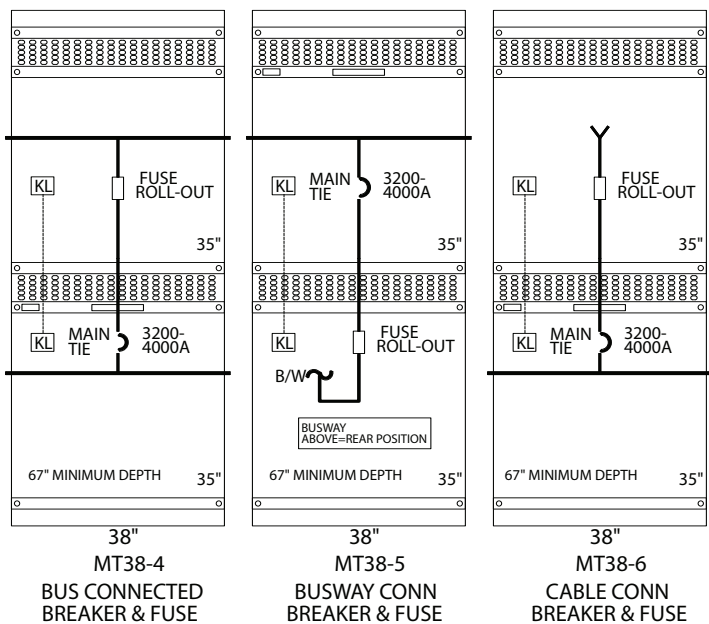
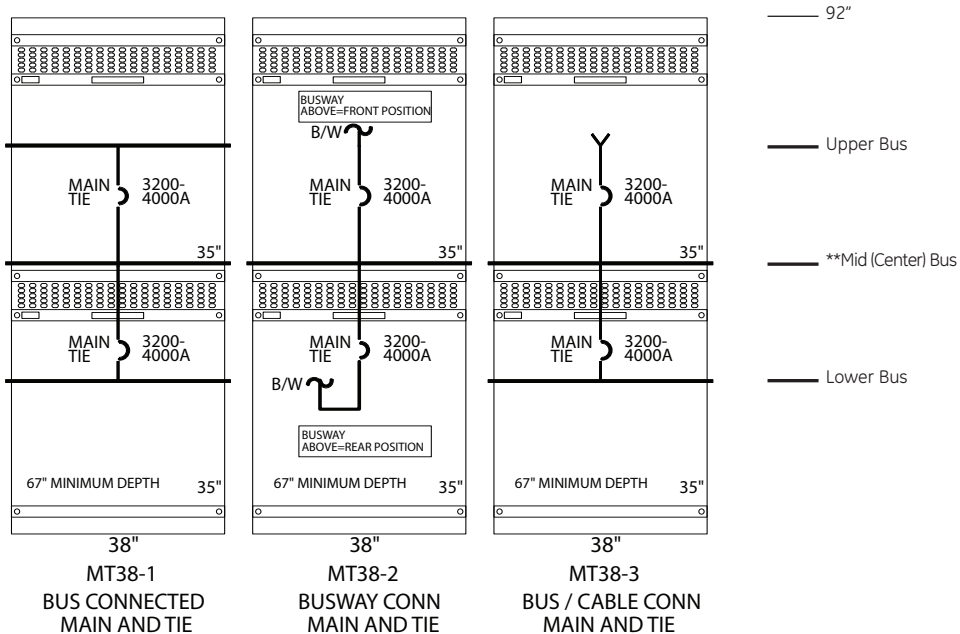

Entellisys 38" Sections (Main, Tie, Auxiliary, Utility Metering)

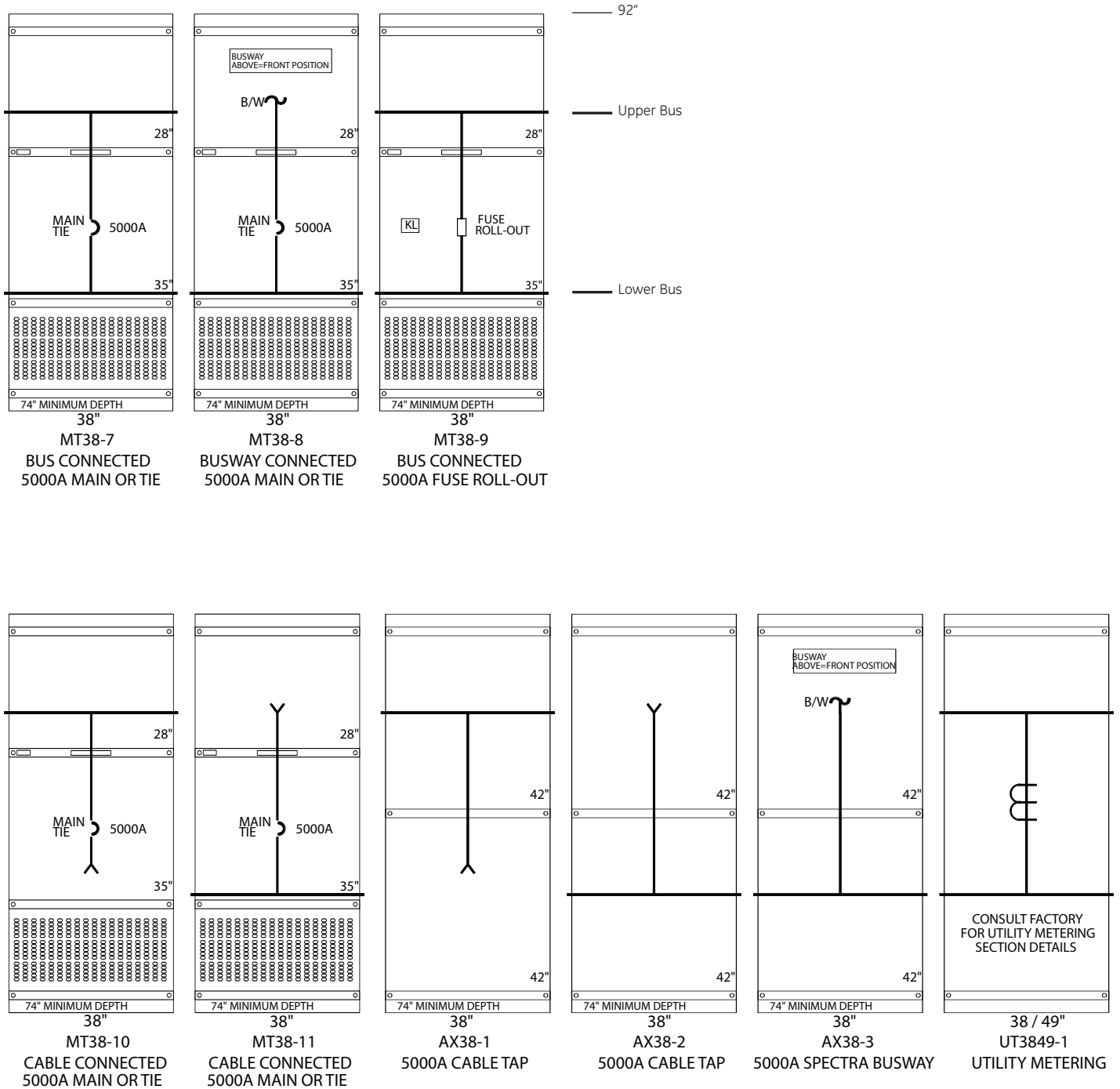
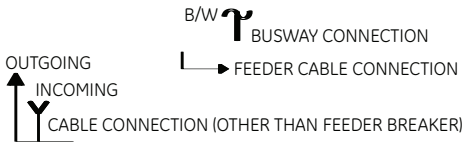

Entellisys Component Placement Rules

Entellisys uses a series of structured cubicle designs to house the components for the system within the switchgear line-up. The structured cubicle design enhances the overall quality of the product by providing repeatable switchgear designs, standardized wire harnesses, and standardized drawings. Each Entellisys system component – CPU, Network Switch, HMI, Control Power Throwover, UPS, Digital I/O, Power Supply – has a preferred location based on its function and characteristics. The component locations address engineering details such as wire harness routing, cubicle ventilation, and proximity to primary devices. The user’s needs are also considered in the location of the components, focusing on convenient access for operation and maintenance, positioning for viewing and programming, and similarity of design for varying switchgear applications.

A number of cubicle designs and locations are available for each system component. This allows the designer to utilize the space remaining in the switchgear line-up after locating all of the circuit breakers and ensures the switchgear footprint

remains as small as practical while maintaining the structured design of the system.

Entellisys components can be located within the switchgear line-up in two different configurations. The standard configuration has the redundant components mounted “together,” meaning the redundant CPUs are mounted in the same cubicle, the redundant UPSs are mounted in the same cubicle, and the redundant network communication switches are mounted in the same cubicle. The other option is to mount the redundant components in “separate” cubicles – the CPUs, UPSs, and network switches each would be mounted in non-adjacent cubicles. In a “separate” configuration, a CPU, UPS, and network communication switch could be in the same cubicle, or these components could each be mounted in individual cubicles.

The standard “system components together” configuration yields the most compact switchgear layout whereas the “system components separated” configuration may require additional cubicles.

Table 16.5
System Components

Configuration	I/O	Circuit Breakers	Components	Cubicle ID ¹
System Components Together (Redundant components are in the same cubicle)	No Digital I/O	≤ 23 Breakers	CPUs, UPSs	(C+J) or W
		> 23 Breakers	CPUs, UPSs	(C+J+T4) or W
	Digital I/O (1-64 Points)	≤ 23 Breakers	CPUs, I/O	O1 or P
		> 23 Breakers	UPS	J
	Digital I/O (65-128 Points)	≤ 23 Breakers	CPUs, UPSs	(C+J)
		> 23 Breakers	I/O	Q or R
System Components Separated (Redundant components are in separate, non-adjacent sections)	No Digital I/O	≤ 23 Breakers	CPUs, UPSs	(L+N) or [(A+B) + (G+H)]
		> 23 Breakers	CPUs, UPSs	[(L+N) + (T2+T2)] or [(U+V) + (G+H)]
	Digital I/O (1-64 Points)	≤ 23 Breakers	CPU-A, I/O	O3
			UPS-A	H
			CPU-B, UPS-B	L
			or	
			CPU-A, I/O	O3
			UPS-A	H
		> 23 Breakers	CPU-B	A
			UPS-B	G
			CPU-A, I/O	O3
			UPS-A	H
			CPU-B, UPS-B	L
			TIERED SWS	(T2+T2)
	or			
	CPU-A, I/O	O3		
	UPS-A	H		
	CPU-B, TIERED SW	U		
UPS-B	G			
TIERED SW FOR CPU-A	T2			
All Systems			HMI (Primary)	D
			HMI (Secondary, optional)	F

¹ Refer to Table 16.6

The following set of rules governs the placement of Entellisys components within the switchgear line-up.

1. Preferred location for the UPS is at the bottom of a section but can be located in an upper compartment provided the UPS is not located above a circuit breaker.
2. HMI is located such that the bottom of the HMI cubicle is 42 to 49 inches above the floor.
3. HMI cannot be located in front of a UPS due to the depth of the UPS.
4. Digital I/O (up to 64 points, redundant or non-redundant) must be in the uppermost cubicle in the section, not above any 100kA IC breakers and not above any 4000A or 5000A breakers.
5. Digital I/O (65 to 128 points) must be located in an auxiliary (non-breaker) section.
6. Redundant Digital I/O requires the standard “system components together” arrangement mentioned above. Redundant Digital I/O cannot be provided when the redundant system components (CPU, Network Switch, and UPS) are located in separate sections.
7. Non-redundant Digital I/O (65-128 points) also requires a “standard system” arrangement.
8. A “system components separated” design requires at least one vertical section between sections containing the redundant system components (CPU, Network Switch, UPS).
9. In a “system components separated” design, the CPUs cannot be located more than 300 feet apart. This is the maximum allowable distance for the communication cables.
10. A Near Gear HMI Section cannot be more than 300 feet from the CPU and HMI Network Switch. This is the maximum allowable distance for the HMI communication cable.
11. For a “standard system” arrangement, the preferred location for the CPUs is in the center of the line-up. This reduces the length of the communication cables.

Tables 16.1 and 16.2 identify the available structured cubicles for Entellisys system components. The subsequent drawings show the possible locations of system components.

Table 16.6
Entellisis System Components Cubicles

Cubicles		Stacks										Hoffman Box	Near Gear Stack
Configuration	Contents	Cubicle ID	22" W			30" W					38" W		
			21" H	42" H		21" H	28" H	35" H	42" H	42" H	42" H		
			Full Depth	Full Depth	1/2 Depth (xfmr trans)	Full Depth	Full Depth	Full Depth	Full Depth	1/2 Depth (EGX bkr)	Full Depth		
System Components Separated – CPU	1-CPU(B), 1-NETWORK SW(B), 1-232 / 485 CONV	A	✓		✓	✓					✓		
	1-CPU(A), 1-NETWORK SW(A), 1-232 / 485 CONV, 1-HMI SW	B i	✓		✓	✓					✓		
	1-CPU(A), 1-NETWORK SW(A), 1-232 / 485 CONV, 1-HMI SW, 1-VPN	B ii	✓		✓	✓					✓		
System Components Together – CPU	2-CPU, 2 NETWORK SW, 1-HMI	C i	✓		✓	✓					✓		
	2-CPU, 2 NETWORK SW, 1-HMI, 1-VPN	C ii	✓		✓	✓					✓		
HMI	HMI (PRIMARY)	D	✓	✓	✓	✓		✓	✓	✓	✓	✓	✓
	HMI (NON-PRIMARY)	F	✓	✓	✓	✓		✓	✓	✓	✓	✓	✓
System Components Separated – UPS	1-UPS, 1-83	G	✓		✓	✓							
	1-UPS, 1-83, 1-232 / 485 CONV, 1-POWER SUPPLY	H	✓		✓	✓							
System Components Together – UPS	2-UPS, 2-83, 1-232 / 485 CONV, 1-POWER SUPPLY	J	✓		✓	✓							
System Components Separated – with UPS	1-CPU(B), 1-NETWORK SW(B), 1-232 / 485 CONV, 1-UPS(B), 1-83	L			✓	✓							
	1-CPU(A), 1-NETWORK SW(A), 2-232 / 485 CONV, 1-HMI SW, 1-UPS(A)	N i			✓	✓							
	1-CPU(A), 1-NETWORK SW(A), 2-232 / 485 CONV, 1-HMI SW, 1-UPS(A), 1-VPN	N ii			✓	✓							
Digital I/O – 64 points	DIGITAL I/O (64 POINTS), 1-INTERFACE BLOCK, RELAY BLOCKS, 1-5V POWER SUPPLY, PLUS C i	O1 i							✓		✓		
	DIGITAL I/O (64 POINTS), 1-INTERFACE BLOCK, RELAY BLOCKS, 1-5V POWER SUPPLY, PLUS C ii	O1 ii							✓		✓		
	DIGITAL I/O (64 POINTS), INTERFACE BLOCKS, RELAY BLOCKS, 1-5V POWER SUPPLY, PLUS N i	O3 i							✓		✓		
	DIGITAL I/O (64 POINTS), INTERFACE BLOCKS, RELAY BLOCKS, 1-5V POWER SUPPLY, PLUS N ii	O3 ii							✓		✓		
Digital I/O – 64 points - redundant	DIGITAL I/O (64 POINTS REDUNDANT), 2-INTERFACE BLOCKS, RELAY BLOCKS, "OR" BOARDS, 1-5V POWER SUPPLY, PLUS C i	P i							✓		✓		
	DIGITAL I/O (64 POINTS REDUNDANT), 2-INTERFACE BLOCKS, RELAY BLOCKS, "OR" BOARDS, 1-5V POWER SUPPLY, PLUS C ii	P ii							✓		✓		
Digital I/O – 128 points	DIGITAL I/O (128 POINTS), 2-INTERFACE BLOCKS, RELAY BLOCKS, 1-5V POWER SUPPLY	Q							✓		✓		
Digital I/O – 128 points - redundant	DIGITAL I/O (128 POINTS REDUNDANT), 4-INTERFACE BLOCKS, RELAY BLOCKS, "OR" BOARDS, 1-5V POWER SUPPLY	R							✓		✓		
Tiered Network Switches	2-TIERED NETWORK SWS (16 PORT), 1-12V POWER SUPPLY, (PLUS 32 NETWORK CABLES)	T2	✓		✓	✓					✓		
	4-TIERED NETWORK SWS (16 PORT), 2-12V POWER SUPPLY, (PLUS 64 NETWORK CABLES)	T4	✓		✓	✓					✓		
System Components Separated – with Tiered Network Switches	1-CPU(B), 3-TIERED NETWORK SWS (1-8 PORT, 2-16 PORT), 1-232 / 485 CONV	U	✓		✓	✓					✓		
	1-CPU(A), 3-TIERED NETWORK SWS (1-8 PORT, 2-16 PORT), 1-232 / 485 CONV, 1-HMI SW	V i			✓	✓					✓		
	1-CPU(A), 3-TIERED NETWORK SWS (1-8 PORT, 2-16 PORT), 1-232 / 485 CONV, 1-HMI SW, 1-VPN	V ii			✓	✓					✓		
System Components Together – in Single Section	STD SYSTEM (NOT SPLIT), NO DIGITAL I/O, ALL COMPONENTS IN ONE SECTION, - (C i or C ii) + (J)	W1									✓		
	STD SYSTEM (NOT SPLIT), NO DIGITAL I/O, ALL COMPONENTS IN ONE SECTION, > 23 BKRS - (C i or C ii) + (J) + (T4)	W2									✓		

Structured Entellisis Cubicle
 Use 21" cubicle plus a 7" or 14" blank or (2)-21" cubicles
 Space not useable or not structured for Entellisis components

A), (B) identify the redundant system components.

Primary HMI is powered from UPS-A and has a communication connection to UPS-A.

"Tiered" network switches are required when the number of breakers in the system is greater than 23 and less than or equal to 30.

Entellisys System Component Cubicles (Transformer Transition, Auxiliary Sections)

Transformer Transition Sections

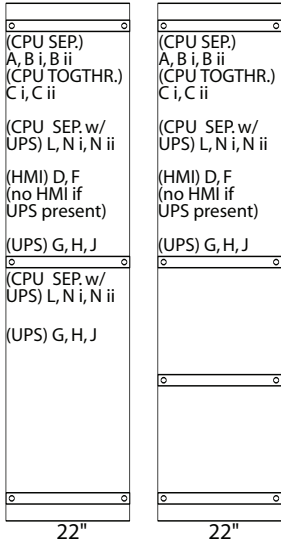

Auxiliary Sections

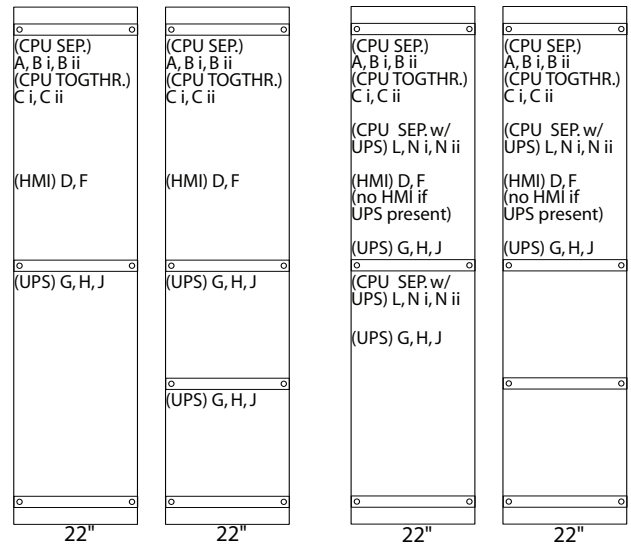

Entellisy System Component Cubicles (Auxiliary Sections)

Auxiliary Sections

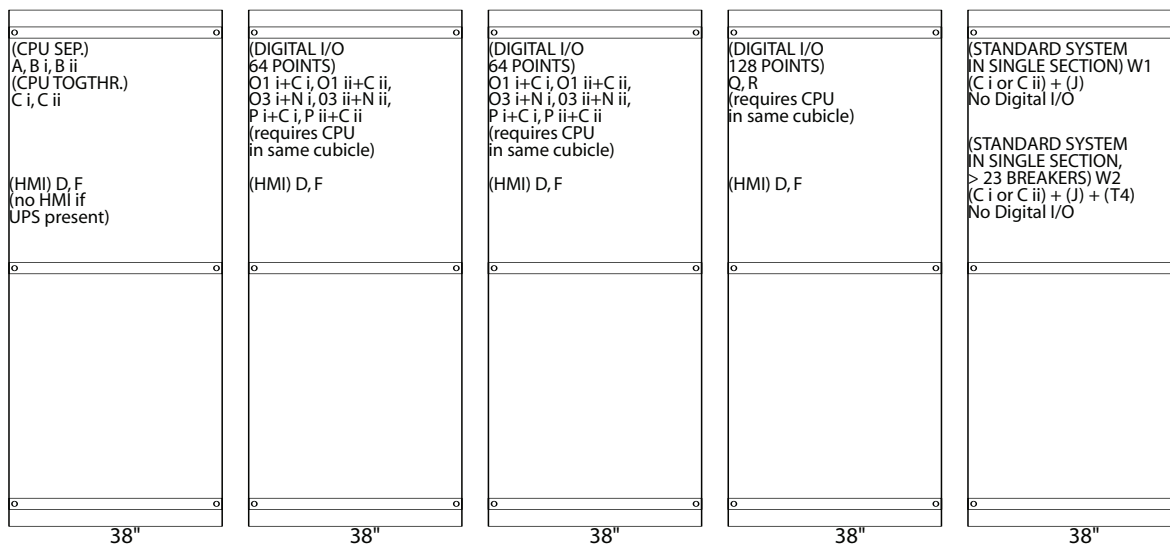
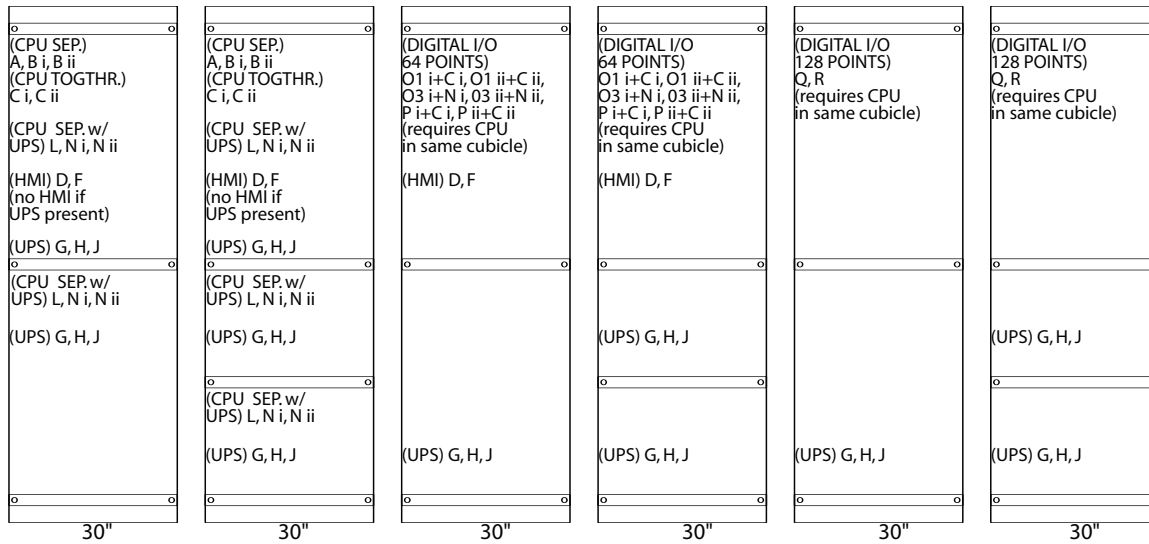

Entellisis System Component Cubicles (Breaker Sections)

Breaker Sections

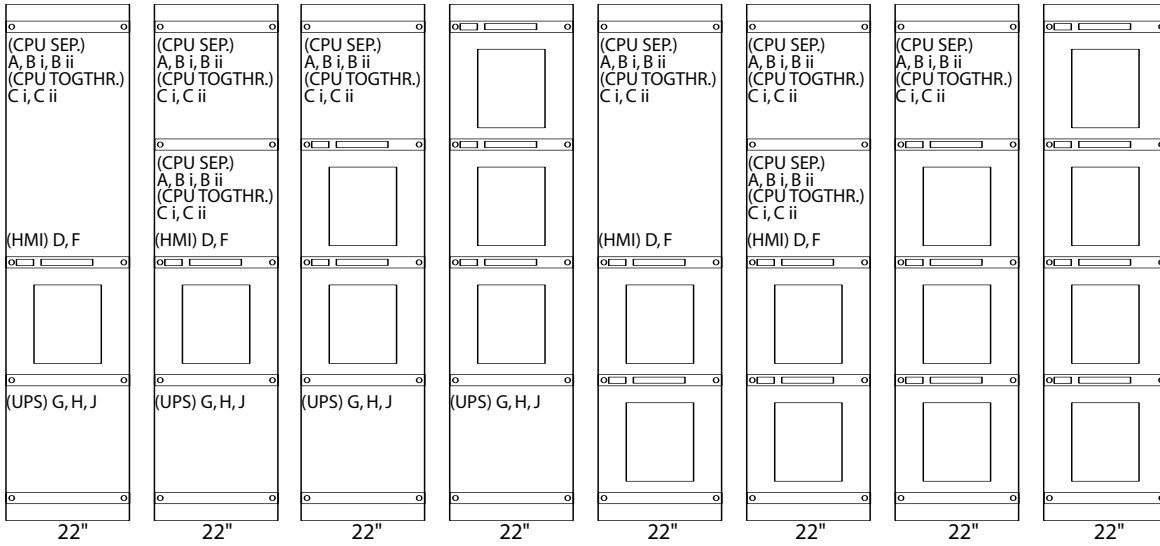

Intermix Sections

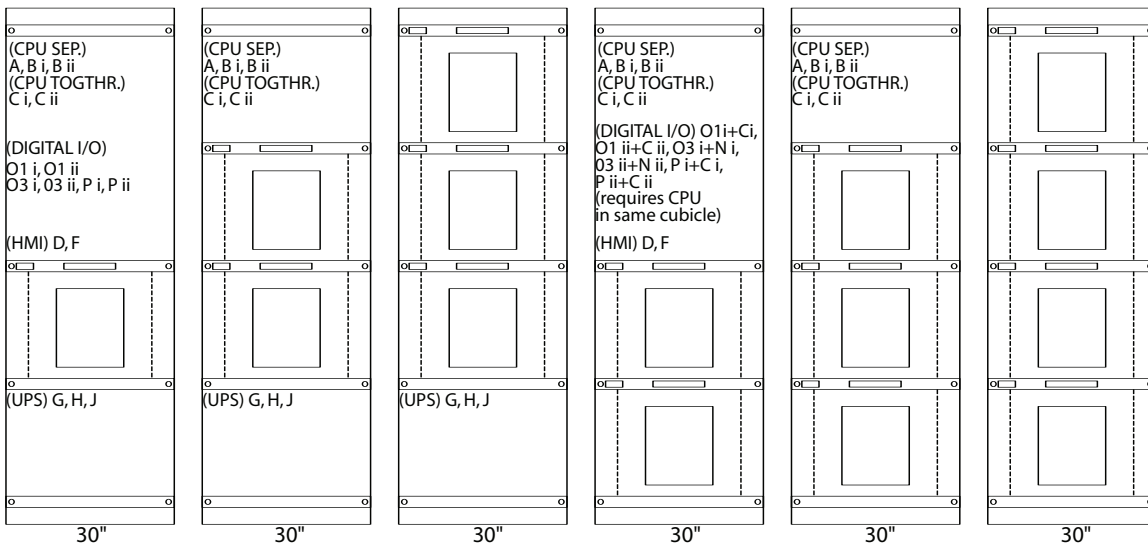

Entellisy System Component Cubicles (Breaker Sections)

Breaker Sections

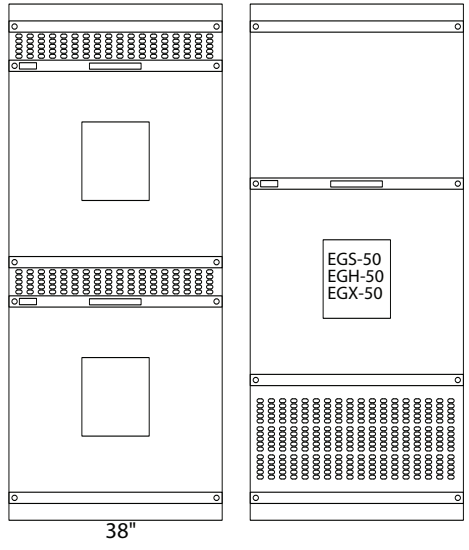
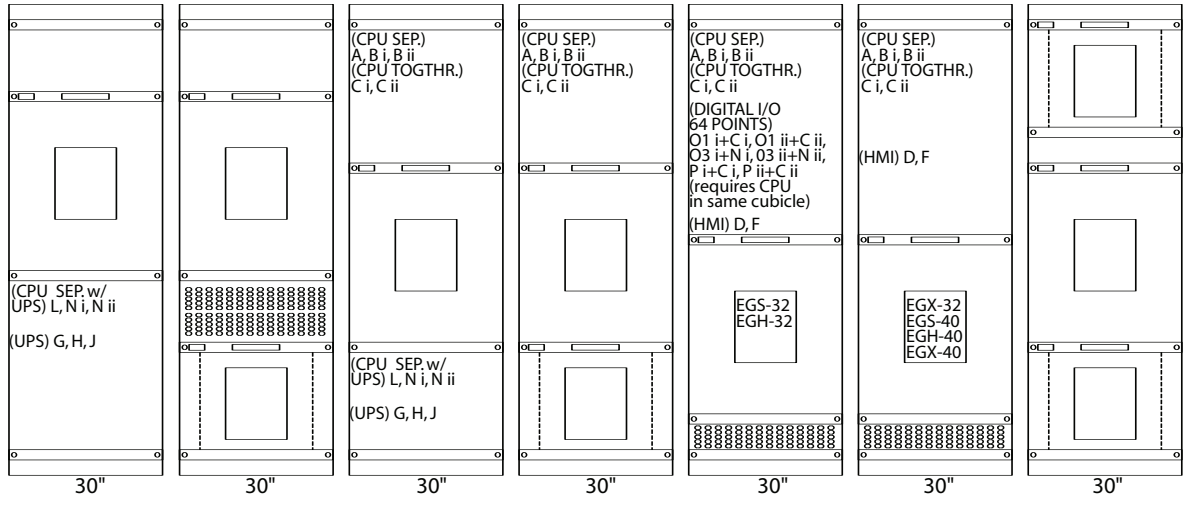

Entellisis System Component Cubicles With Tiered Network Switches (Breaker, Transformer Transition, Auxiliary Sections)

Breaker Sections

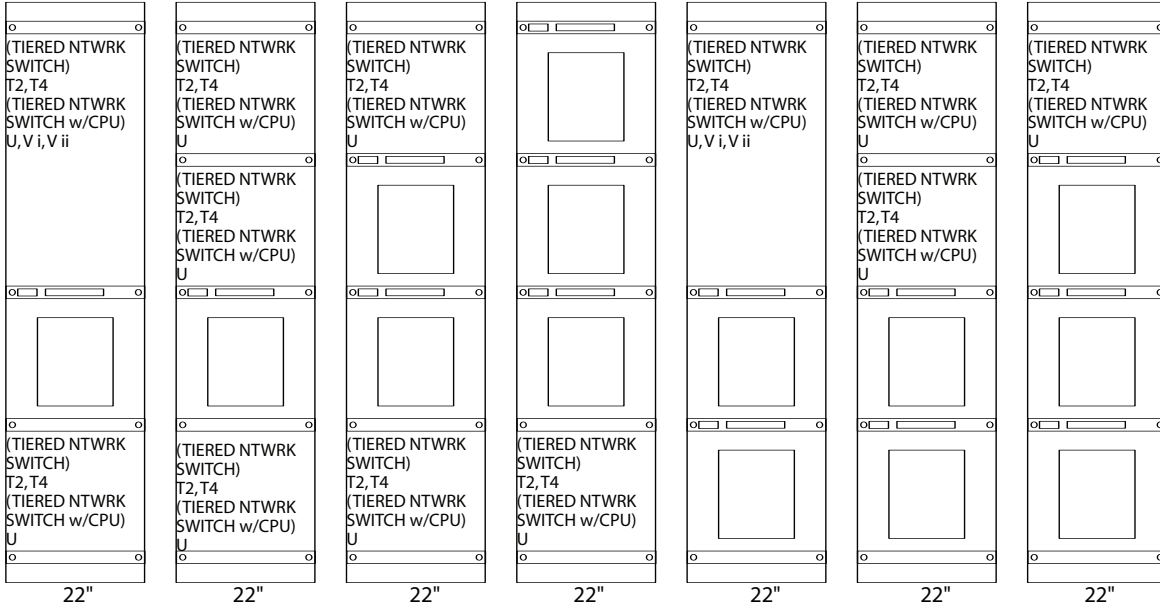

Transition

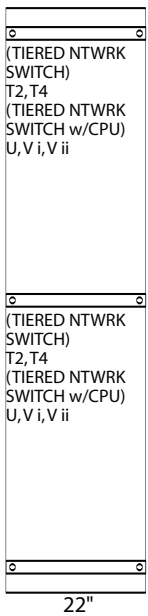

Auxiliary Sections

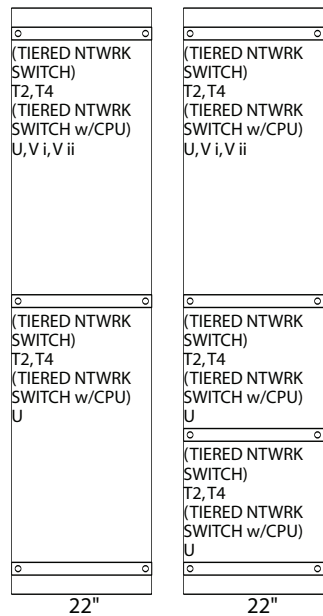

Auxiliary Sections

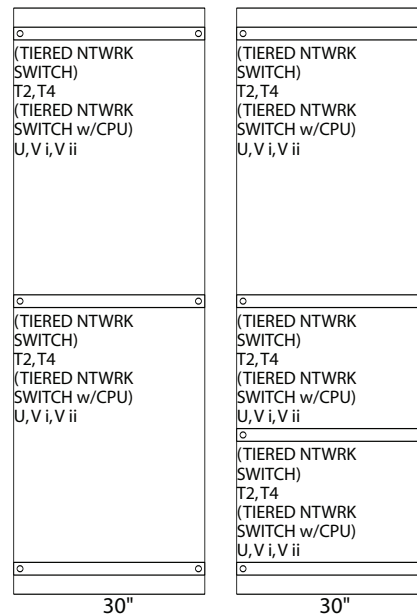

Entellisys System Component Cubicles With Tiered Network Switches (Breaker Sections)

30" Intermix Sections

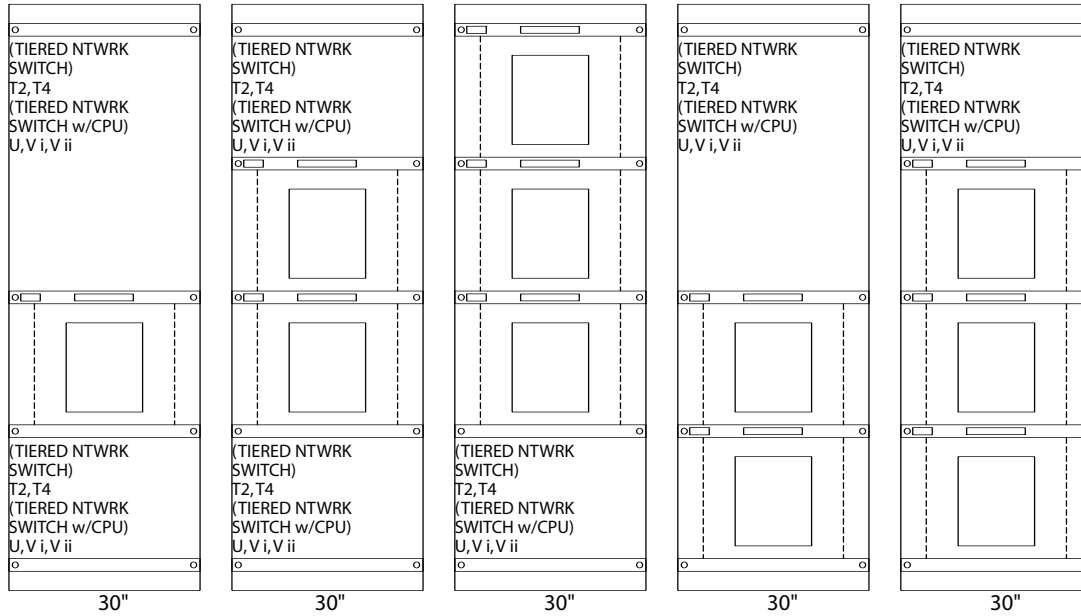

30" Breaker Sections

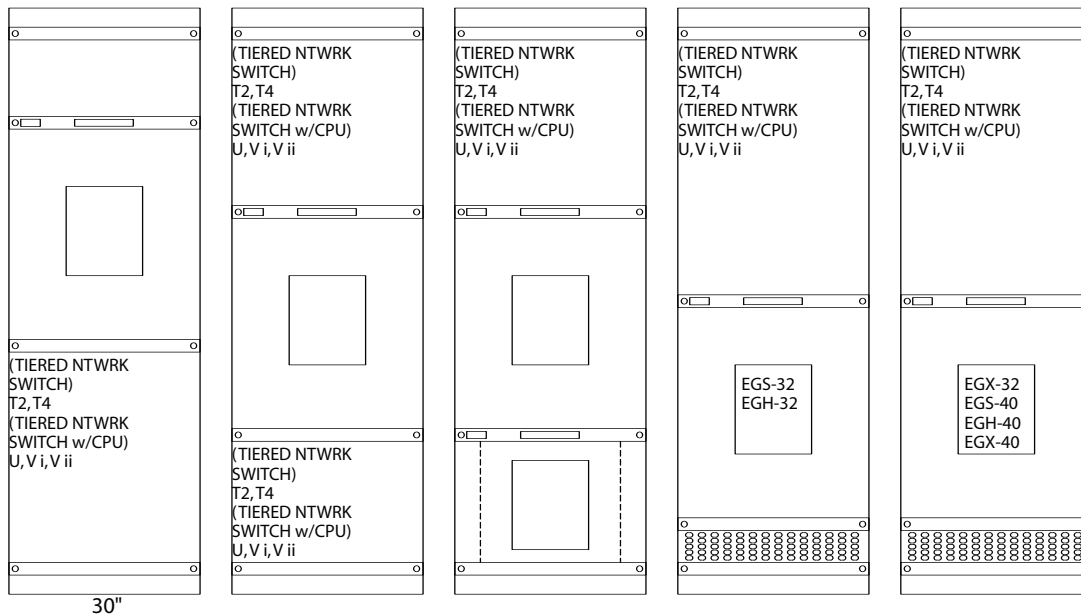

Entellisys Floor Plans and Side Views

NEMA 1 indoor – side view and anchoring details

Note: Refer to installation drawing and Entellisys switchgear installation manual (DEH-237) for additional information.

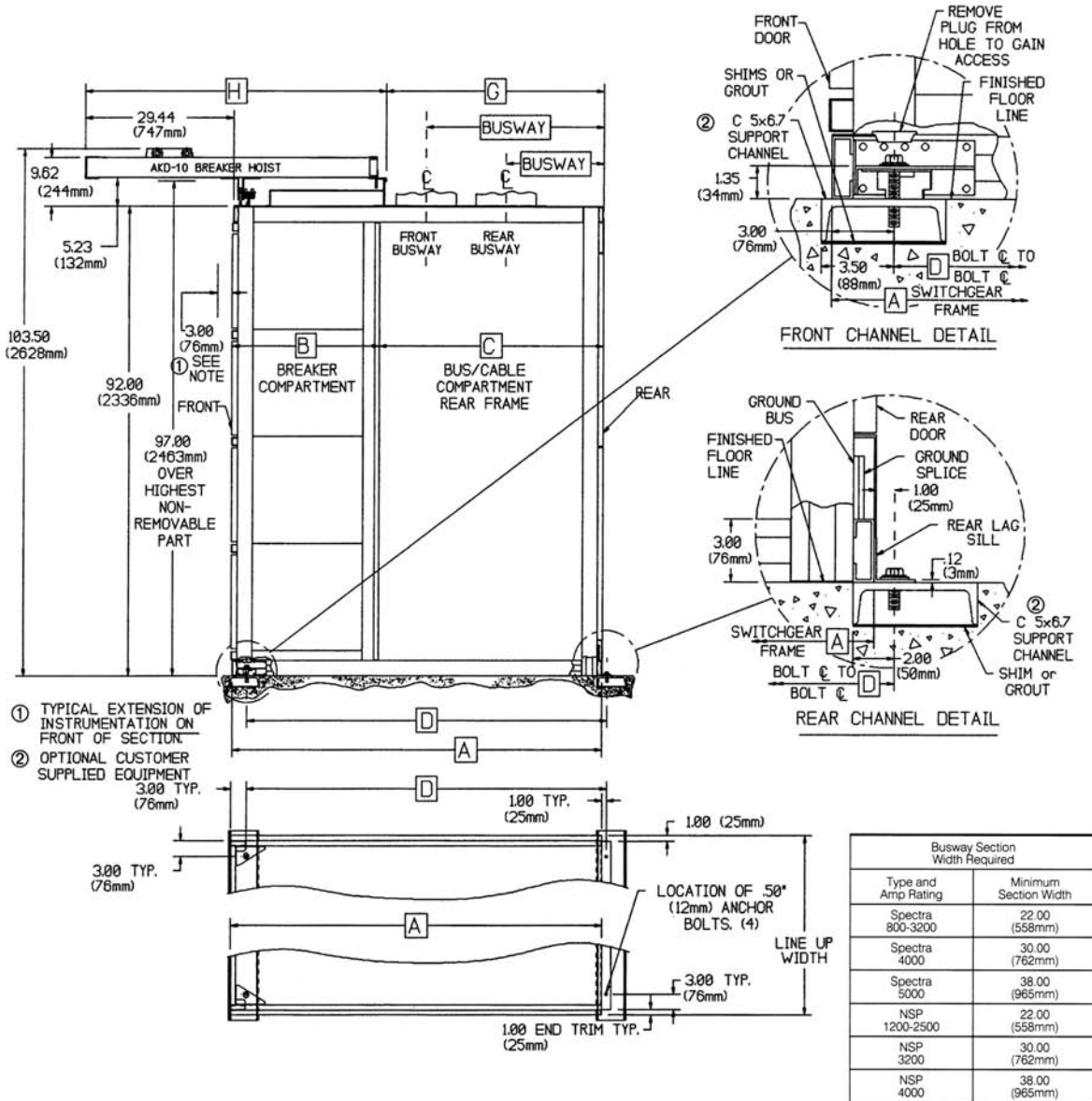

A Equipment Depth	B Breaker Compartment	C Rear Frame Depth	D Anchor Bolt Spacing	G Back of Hoist to Rear Frame	H Hoist Length	Busway Locations				
						Front			Rear	
						Spectra 800-4000 Amp NSP 1200-3200 Amp	NSP 4000 Amp	Spectra 5000 Amp	Spectra 800-4000A	NSP 1200-3200A
60.00 (1524mm)	30.00 (762mm)	30.00 (762mm)	58.00 (1473mm)	29.34 (745mm)	60.10 (1526mm)	21.50 (546mm)	19.50 (495)	N/A	9.50 (241)	N/A
67.00 (1701mm)	30.00 (762mm)	37.00 (938mm)	65.00 (1651mm)	36.34 (923mm)	60.10 (1526mm)	28.50 (723mm)	26.50 (673)	23.50 (596)	16.50 (419)	12.50 (317)
67.00 ^③ (1701mm)	37.00 ^③ (939mm)	30.00 ^③ (762mm)	65.00 ^③ (1651mm)	29.34 ^③ (745mm)	67.10 ^③ (1704mm)	21.50 ^③ (546mm)	19.50 ^③ (495)	N/A ^③	9.50 ^③ (241)	N/A ^③
74.00 (1879mm)	30.00 (762mm)	44.00 (1117mm)	72.00 (1828mm)	43.34 (1100mm)	60.10 (1526mm)	35.50 (901mm)	33.50 (850)	30.50 (774)	23.50 (596)	19.50 (495)
74.00 ^④ (1879mm)	37.00 ^④ (939mm)	37.00 ^④ (939mm)	72.00 ^④ (1828mm)	36.34 ^④ (923mm)	67.10 ^④ (1704mm)	28.50 ^④ (723mm)	26.50 ^④ (673)	23.50 ^④ (596)	16.50 ^④ (419)	12.50 ^④ (317)
81.00 ^④ (2057mm)	37.00 ^④ (939mm)	44.00 ^④ (1117mm)	79.00 ^④ (2006mm)	43.34 ^④ (1100mm)	67.10 ^④ (1704mm)	35.50 ^④ (901mm)	33.50 ^④ (850)	30.50 ^④ (774)	23.50 ^④ (596)	19.50 ^④ (495)

③ If line-up includes any EGF-08/16 breakers

④ If line-up includes any EGS/EGX-50 or EGF-08/16 breakers

Refer to Table 16.1 and 16.2 for equipment depth options

Entellisys Floor Plans and Side Views

NEMA 1 indoor – floor plan and cable space details

Note: Refer to installation drawing and Entellisys switchgear installation manual (DEH-237) for additional information.

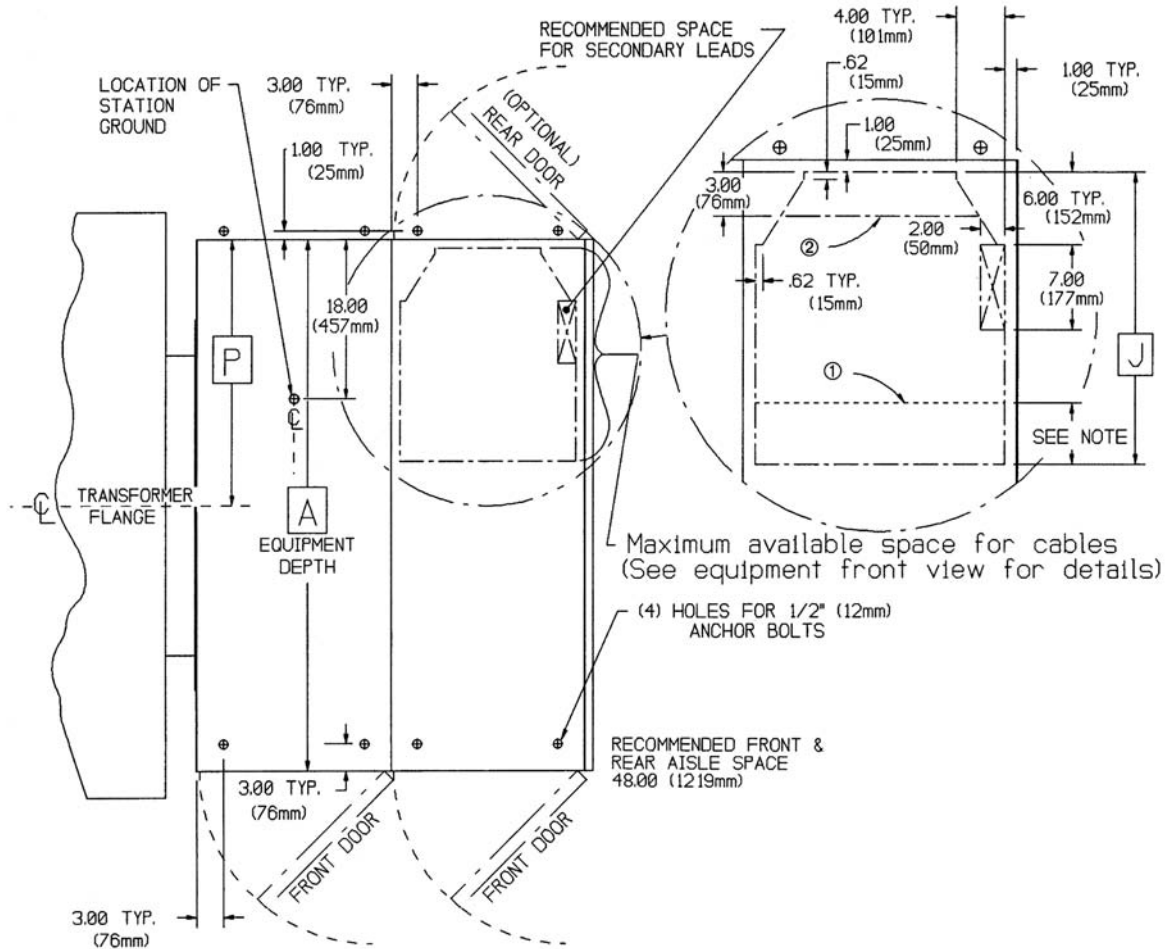

- ① **Cables above** – available space for cables reduced by 5.00" (127mm) if **BUS COMPARTMENT BARRIERS** are provided
- Cables below** – available space for cables reduced by 4.00" (101mm) if 800-2000A breaker is located in bottom compartment
- Cables above or below** – available space for cables reduced by 3.00" (76mm) for any section containing a 5000A BUS (if bus compartment barriers are supplied, see note above)
- ② Space required for UPPER neutral with leads ABOVE or LOWER neutral with leads BELOW

A Equipment depth	Direction of cables	J	Rear extension depth	P Transformer flange CL to rear of switchgear
60" non-fused OR 67" with fused EGF-08/16	Below	19.00 (482mm)	None	26.50 (673mm)
	Above	24.00 (609mm)		
67" non-fused OR 74" with fused EGF-08/16	Below	26.00 (660mm)	7.00 (177mm)	33.50 (851mm)
	Above	31.00 (787mm)		
74" non-fused OR 81" with fused EGF-08/16	Below	33.00 (838mm)	14.00 (355mm)	40.50 (1029mm)
	Above	38.00 (965mm)		
74" with EGS / EGX-50	Below	19.00 (482mm)	None	26.50 (673mm)
	Above	24.00 (609mm)		
81" with EGS / EGX-50	Below	26.00 (660mm)	7.00 (177mm)	33.50 (851mm)
	Above	31.00 (787mm)		
67" with 5000 Amp bus w/o EGS / EGX-50 w/o EGF-08 / 16	Below	19.00 (482mm)	None	29.50 (749mm)
	Above	24.00 (609mm)		
74" with 5000 Amp bus w/o EGS / EGX-50 w/o EGF-08 / 16	Below	26.00 (660mm)	7.00 (177mm)	36.50 (927mm)
	Above	31.00 (787mm)		

Refer to Table 16.1 and 16.2 for equipment depth options.

Notes

Entellisys Low-Voltage Switchgear

Appendix A. Guide Form Specification

Following is Section 2 of the CSI Guide Form Specification. Where appropriate, select items in brackets that correspond to your particular needs. For a complete CSI specification, please see www.entellisys.com.

PART 2 PRODUCTS

2.01 DESIGN

- A. General Electric Entellisys low voltage metal enclosed integrated switchgear system has been used as the basis for design for this project.
- B. The first source of general information shall be these general specifications; however, detailed and specific information contained in the drawings will take precedence over these general specifications as the drawings contain project specific information. In the event of a conflict between the plans and specifications, the owner/engineer will determine which is correct.

2.02 EQUIPMENT LINE-UP INFORMATION

- A. The General Electric Entellisys low voltage metal enclosed integrated switchgear system lineup shall be completely factory assembled and shall contain upper, lower and side metal compartmentalized units for removable power circuit breakers. Switchgear assemblies and breakers shall be constructed by one manufacturer.
- B. The General Electric EntelliGuard circuit breaker are to be low voltage metal frame power circuit breakers (air circuit breakers). Use of, or substitution by insulated case circuit breakers, molded case circuit breakers or any protective device containing a non-metal frame is unacceptable and will be rejected by the owner/engineer.
- C. The manufacturer shall provide approval and record documentation in an all [electronic][paper] format.
- D. The following factory accommodations are required for this project:
 - 1. Factory certified test reports [are not required as normal factory testing procedures are acceptable.][shall be issued at the conclusion of the factory testing.]
 - 2. Factory witness testing [is not required as normal factory testing procedures are acceptable.][shall be provided.]
 - 3. Customer inspection [is not required as normal factory testing procedures are acceptable.][shall be provided so that the owner/engineer/owner's representative can visit the factory and view the assembled equipment prior to its shipment.]

2.03 EQUIPMENT SUMMARY INFORMATION

- A. The low voltage metal enclosed integrated switchgear system lineup shall be engineered and fabricated to meet the specific project electrical distribution, protection and control requirements as detailed in this specification. The specific equipment lineup properties listed below.
- B. Equipment construction shall house all live components in a grounded metal enclosure 92 inches high with an code gauge modular designed steel frame with removable plates. The overall lineup enclosure construction type shall be as [Indoor type NEMA 1.][Indoor type NEMA 1 Dripproof.]
- C. To facilitate the ease of equipment assembly and installation, the MAXIMUM equipment shipping split section width

shall be [120 inches to minimize the amount of assembly sections.][38 inches to provide individual vertical stacks which will allow easier egress to the final location.]
[Insert width of inches.]

- D. When shipped from the factory the packaging shall be [standard domestic factory packaging (poly wrapped, cardboard/styrofoam cushions, etc.), special export packaging is not required.][suitable for special conditions, special export packaging is required.]
- E. The switchgear lineup shall be rated and labeled to receive a power supply Line-to-Line voltage rating as shown on the project drawings.
- F. The switchgear lineup shall be rated and labeled to receive a phasing and wire arrangement as shown on the project drawings.
- G. The switchgear lineup shall be rated and labeled to receive a frequency rating as shown on the project drawings.
- H. All bus bars in the switchgear lineup shall be braced and labeled to withstand the short circuit mechanical as shown on the project drawings.
- I. The main bus in the switchgear lineup shall be made of copper and shall be rated and labeled to handle an electrical load as shown on the project drawings.
- J. The overall short circuit value of the switchgear lineup shall be rated and labeled as shown on the project drawings.
- K. A ground bus shall be secured to each vertical section structure. It shall also extend entire length of switchgear lineup and shall be equipped with a 4/0 terminal for connection to the building's ground system. The ground bus in the switchgear lineup shall be made of copper and shall be rated as shown on the project drawings.
- L. To facilitate the ease of dressing the exiting cables, the equipment ground bus shall be positioned on at the same locations [top][bottom] as the majority of exiting cables.
- M. If provided, the copper neutral bus shall be mounted on stand off insulators to isolate it from ground and shall be sized as shown on the project drawings.
 - 1. If a neutral bus is provided, it shall be located opposite of the ground bus to facilitate the ease of dressing the exiting cables.
 - 2. If a neutral bus is provided, the configuration of the neutral system shall be [standard 4-wire WYE][3-wire WYE GROUNDED][3-wire HIGH RESISTANCE GROUNDED][3-wire HIGH RESISTANCE GROUNDED system and a high resistance ground CT is required].
- N. In order to provide improved personnel safety from the front of the equipment, the main and riser busses shall be situated behind a metal barrier so that the breaker compartments, instrument compartments and auxiliary compartments are all shielded from the main & riser buswork. The bussing itself shall be [a bare bus system][an insulated/isolated bus system][a bus compartmentation system][an insulated/isolated and compartmented bus system].
- O. The same material shall be used at the vertical-to-horizontal bus connections and at points where vertical

bus connects to bus bars supplying power to circuit breaker compartments. All bus material and plating in the switchgear lineup shall be [copper buses with full silver joint plating][copper buses with tin plating].

- P. All bus hardware shall be high tensile strength zinc chromate plated steel with [standard factory connectors][special Belleville washers].
- Q. The vertical bus shall be held rigid in support structure of short circuit resistant, molded glass reinforced polyester bases to inhibit the spread of arcing faults. All bus bars shall be arranged to permit the addition of future additions.
- R. The switchgear shall have rear cable terminal compartments. The cable bending space shall meet National Electrical Code requirements.
- S. The overall equipment lineup depth shall be as shown on the project drawings.
- T. The lineup shall have [no additional rear extension][a 7" rear extension][a 14" rear extension].
- U. The lineup shall be painted using a two step process. In step one a light gray paint shall be applied using an epoxy electro-deposition process. In step two the paint shall be over sprayed on the exterior surfaces. The final color of the equipment shall be [standard General Electric ANSI 61 gray][ANSI 24 gray][ANSI 45 gray][ANSI 70 gray] **[Insert special paint color]**.
- V. The interior of the equipment shall be [standard, the front and rear interior compartments shall be the same color as the exterior color][special, the front and rear interior compartments shall be painted white][special, the front interior compartments shall be painted white].

2.04 EQUIPMENT OPTIONS – ELECTRICAL

- A. Identification of the control wiring within the equipment lineup shall be provided with wire sleeves, the sleeves will identify the origin and destination of that specific wire/circuit.
- B. Wire terminals for the control wiring within the equipment lineup shall be [standard spring spade insulated terminals][special ring insulated terminals][special spring space non-insulated terminals], except where ring terminals are used to connect C/T circuits.
- C. Minimum wire size for the control wiring within the equipment lineup shall be [No. 14 AWG][No. 12 AWG][10 AWG], extra flexible, stranded, tinned-copper, type SIS cross-linked polyethylene, rated 600 volts, except for specific circuits requiring larger wire.
- D. Wire terminals for the C/Ts (current transformers) within the equipment lineup shall be crimp type [standard, non-insulated ring terminals][special, insulated ring terminals].
- E. Minimum wire size for the C/Ts (current transformers) within the equipment lineup shall be [No. 14 AWG][No. 12 AWG][No. 10 AWG], extra flexible, stranded, tinned-copper, type SIS cross-linked polyethylene, rated 600 volts.
- F. Control power for the equipment lineup shall be 120 VAC. Refer to the project drawings for the source location, required components and configuration.

- G. The equipment lineup shall be provided with [no heaters][heaters located in each vertical stack rear cable compartment and shall be controlled by the devices listed below][heaters located in each vertical stack rear cable compartment as well as the front instrumentation compartment. The strip heater shall be controlled by the devices listed below].
 - 1. If equipment strip heaters are provided, they shall be controlled by [an installed thermostat][an installed humidistat][an installed heater switch][both an installed thermostat and installed humidistat] The heaters installed in the lineup are not required to be controlled by an installed humidistat.
 - 2. If equipment strip heaters are provided, they shall [not be monitored][be monitored by a heater ammeter].

2.05 EQUIPMENT OPTIONS – MECHANICAL

- A. The following general equipment options shall be provided:
 - 1. A breaker door interlock [is not required, provide the standard door mechanism assembly][is required].
 - 2. Device door barriers are not required as all control wiring on back panels are rated 120V or less per ANSI requirements.
 - 3. Rear floor plates [are not required, provide the standard open rear cable area][shall be provided, the installer/contractor shall punch the plates to provide access for the conduits].
 - 4. A test kit [is not required as the GE Entellisys integrated switchgear system is self-monitoring with an extensive diagnostic routine. Non GE Entellisys systems shall provide a test kit][shall be provided].
 - 5. Insect screens in the equipment lineup [are not required][shall be supplied].
 - 6. A remote racking mechanism [is not required][shall be provided, as there is a need to minimize arc flash opportunity. This will allow the operator rack a breaker in/out up to 30 feet away from the front of the equipment].
 - 7. A test cabinet for the circuit breakers (EntelliGuard) [is not required][shall be provided].
 - 8. The equipment lineup [requires no hoist rails or hoist mechanism][is an indoor type NEMA 1 dripproof assembly, as such no hoist rails or hoist mechanism can be provided][requires a set of hoist rails on top of the switchgear lineup][required a set of hoist rails on top of the switchgear lineup and an integral hoist mechanism].
 - 9. The equipment lineup [requires no external hydro crane or lift truck][is an indoor type NEMA 1 dripproof, and requires a portable hydro crane lifting device.] [Additionally, a lift truck shall also be supplied to provide a convenient method to transport the removed circuit breakers.]
 - 10. Section barriers consisting of metal and polyester vertical barricades between sections shall be provided [between the main and feeder sections][between all sections].
 - 11. Drawout compartment shutters used to protect operators from accidental contact with breaker stabs when the breaker is withdrawn from its cubicle shall be provided on [only the Main and Tie breaker cubicles][all breaker cubicles in the lineup].
 - 12. The equipment line-up shall be provided with [no additional sub base][a 4 inch high sub].
- B. The following equipment certifications shall be provided:
 - 1. [There is no requirement for a UL label on the lineup. The equipment shall be manufactured per the most recent appropriate NEMA and ANSI standards.][A UL 1558 label shall be provided on the equipment verifying that the lineup meets all requirements for UL for metal-enclosed low voltage power circuit breaker switchgear.

2. The switchgear lineup shall be constructed [to regular design parameters][to meet the requirements of seismic zones 2A or 2B][to meet the requirements of seismic zone 4].
 3. The equipment shall be manufactured to meet the applicable requirements of the governing bodies cited in the REFERENCES section.
 4. There is [no need for a UL service entrance label on this equipment][a requirement for a UL service entrance label].
- C. The following door, cover and latch requirements shall be provided:
1. The rear of the switchgear shall be provided with [standard bolted covers][hinged rear doors, split height type][hinged rear doors, full height type].
 2. Access to the rear compartment of the switchgear shall [not require any additional provisions][require rear door padlocking provisions].
 3. Opening the rear [covers shall be accomplished by removing the corner bolts][doors shall be accomplished using a T-handle mechanism].
 4. Securing the rear [covers shall be accomplished by tightening the corner bolts][doors shall be accomplished using a three point catch to secure the door at the top, bottom and side].
 5. Service into the rear sections [shall be accomplished by removing the rear covers][shall be accomplished using rear door stops, this will allow the doors to be locked into to open position].
 6. Locks on the rear section [are not required][doors shall be provided].
 7. The switchgear front doors shall [shall have standard 1/4 turn latches][shall have 1/4 turn latches with padlocking provisions][shall have 1/4 turn latches with a keylock].
- D. The equipment lineup shall be supplied with the following cable lugs, pull boxes and cable supports:
1. Conductors shall terminate into [compression lugs] [clamp lugs (mechanical type)]. Refer to the project drawings for quantity and size information.]
 2. The supplied lugs shall be made of [copper][aluminum] and shall be manufactured by Burndy.
 3. The direction of the cables feeding / being fed from the equipment is detailed on the project drawings.
 4. The switchgear lineup shall be provided with [standard rear cable space.][a 15 inch high pull box.][a 22 inch high pull box.][a 29 inch high pull box.] As [no pull box is required, no cable supports or section barriers are required.][a pull box is being supplied, cable supports shall be supplied.][a pull box is being supplied, section barriers shall be supplied.][a pull box is being supplied, cable supports and section barriers shall be supplied.]
- E. The following equipment mimic bus shall be provided:
1. [The standard – no mimic bus requirement is needed.] [A mimic bus shall be provided on the front of the equipment to diagrammatically show the internal bus structure of the lineup. The details of the mimic shall be as detailed below:]
 - a. If mimic bus is provided, it shall be mounted to the equipment using [adhesive vinyl][standard screws][stainless steel screws].
 - b. If mimic bus is provided, the mimic bus size shall be [1/4 inch wide][3/8 inch wide][1/2 inch wide][3/4 inch wide][1 inch wide].
 - c. If mimic bus is provided, the mimic bus color shall be [red][orange][brown][green][blue][black][yellow][white].

2.06 SPECIAL FUNCTIONALITY (ENTELLISYS OPTIONS)

- A. The General Electric Entellisys low voltage metal enclosed integrated switchgear system has been chosen as the basis of design given its flexibility, modularity and overall functionality. The Entellisys system parameters are detailed below. Should the Entellisys system not be provided, the same functionality must be provided to be considered as an acceptable equal. Failure to provide the Entellisys system or the specified functionalities is unacceptable and will result in the proposal being rejected by the owner/engineer.
- B. Each low voltage switchgear lineup shall be supplied with a means to view the status of the overall equipment, breakers, etc as detailed below. The preferred interface is the GE Entellisys HMI, other touch screen displays containing the parameter functionality listed below will be considered equal.
1. The HMI color view screen will be a backlit liquid crystal display (LCD) and have a minimum diagonal viewing area of at least 15 inches.
 2. The HMI shall also contain: a frame integral keyboard, a frame integral number pad with directional arrows, and two USB ports located at the front.
- C. The quantity of HMI devices located in the equipment lineup, which would allow local user interface, shall be [zero] [one][two][three], the location of the lineup display(s) shall be as shown on the project drawing front elevation view.
- D. The quantity of HMI devices located in a near gear stand alone equipment stack, which would allow for remote user interface with the equipment lineup shall be [zero] [one][two][three][four], the location of the near gear displays shall be as shown on the project drawings].
- E. The quantity of HMI devices located in a near gear wall mounted unit, which would allow for remote user interface with the equipment lineup shall be [zero][one][two][three] [four], the location of the near gear displays shall be as shown on the project drawings].
- F. The primary HMI location shall be in the [equipment lineup][near gear stand alone equipment stack][near gear wall mounted unit].
- G. To assure maximum uptime and operational reliability the system shall be provided with two central processing units (CPUs). Use of dual/redundant programmable logic controllers (PLCs) that provide the same parameter functionality will be considered equal.
- H. As there is a need to provide reliable ongoing 120VAC control power for the two CPUs, the system shall be provided with two uninterruptible power supplies (UPS) – one for each CPU. The UPSs shall receive their power from the source specified earlier under the EQUIPMENT LINE-UP INFORMATION part of this specification.
- I. The physical placement of the redundant devices (two CPUs and two UPSs) shall be as [a together placement.] [a separated placement.]
- J. The Entellisys system provides a wide variety of protection functions, metering functions, relaying functions, transfer functions and signaling functions. Following are the specific requirements that must be supplied in the equipment lineup.
1. Zone selective interlocking [is not required for this

- project.)[shall be provided. The system shall be dynamic, allowing for changing ZSI circuit breaker relationships depending on which mains and ties are closed.]
- a. If provided the zone selective interlocking system shall be supplied for interlocking [only the short-time characteristics of the breakers.][only the ground fault characteristics of the breakers.][both the short-time and the ground fault characteristics of the breakers.]
 - b. Refer to the project drawings for details of the zone(s).
2. Bus differential protection [is not required for this project.][shall be provided via the Entellisis zone-based Bus Differential feature.]
 3. The number of ZSI/Bus Differential Zones [is zero.][is one, refer to the project drawings for details of this zone.][is two, refer to the project drawings for details of the zones.][is three, refer to the project drawings for details of the zones.][is four, refer to the project drawings for details of the zones.]
 4. Multi-source ground fault protection [is not required for this project.][shall be provided as there is a need to provide selectivity within the ground fault protection scheme of the lineup.]
 5. The switchgear lineup is [not arranged for multiple sources and there is no need to parallel sources.] [connected to multiple power sources and there is a need to momentarily parallel the sources, as such one sync check relay shall be provided.][connected to multiple power sources and there is a need to momentarily parallel the sources, as such two sync checks relay shall be provided.]
 6. The system ground fault scheme [is not a high resistance ground fault type, therefore no HRG detection system is required.][associated with the equipment lineup is a high resistance ground fault type, therefore provide a system that will detect and alarm in HRG faults.]
 7. The lineup shall utilize [the standard protective settings associated with all the breakers. No enhanced low energy let-thru option is required.][and be provided with a low energy let-thru mode.]
- K. The following metering parameters shall be supplied in the equipment lineup.
1. The BASIC metering package shall include the following metering functions and every breaker in the lineup shall contain these functions. The values listed below shall be displayed on the equipment lineup HMI interface
 - a. Amperes phase A, B, C, amperes of the neutral (on a 4 wire system)
 - b. Volts phase A-B, volts phase B-C, volts phase C-A
 - c. When the lineup is connected to a WYE system, these additional functions shall also be available - Volts phase A-N, B-N, C-N, phase-to-neutral 3-phase average voltage
 2. [In addition to the BASIC metering package, the following EXPANDED metering package shall be provided. The values listed below shall be displayed on the equipment lineup HMI interface.
 - a. The energy based parameters of Positive Real Energy, Negative Real Energy, Positive Reactive Energy, Negative Reactive Energy, and Apparent Energy
 - b. The power based parameters of Real Power, Reactive Power, Apparent Power, Power Factor, Minimum Power Factor and Maximum Power Factor
 - c. As the Entellisis system provides the ability to move the EXPANDED metering package from breaker to breaker the following total number of EXPANDED metering packages shall be provided:
 - 1) Provide [One][Two][Three][Four][Five][Insert the number of EXPANDED metering packages] EXPANDED metering package for the lineup.
 - 2) The end user shall be able to move this package from breaker to breaker via the lineup HMI interface. If the provided metering devices does not have the ability to move from breaker to breaker, then ALL breakers MUST be supplied with the EXPANDED metering functions listed above.
 - d. The GE Entellisis system shall provide the ability add additional EXPANDED metering packages to the lineup via a software/firmware platform. No hardware cost shall be added for these enhancements (just the cost of the software/node module.)
 3. [In addition to the BASIC and ENHANCED metering, the following DEMAND metering package shall be provided. The values listed below shall be displayed on the equipment lineup HMI interface.
 - a. Previous interval kilowatt (kW) demand, Maximum kW demand, Previous interval kilovar (kvar) demand, Maximum kvar demand, Previous interval kVA demand, Maximum kVA demand
 - b. Demand logging for kWh, kvarh, kVAh, kW demand, kvar demand, kva demand, power factor
 - c. As the Entellisis system provides the ability to move the DEMAND metering package from breaker to breaker the following total number of DEMAND metering packages shall be provided:
 - 1) Provide [One][Two][Three][Four][Five][Insert the number of DEMAND metering packages] DEMAND metering package for the lineup.
 - 2) The end user shall be able to move this package from breaker to breaker via the lineup HMI interface. If the provided metering devices does not have the ability to move from breaker to breaker, then ALL breakers MUST be supplied with the DEMAND metering functions listed above.
 - d. The GE Entellisis system shall provide the ability add additional DEMAND metering packages to the lineup via a software/firmware platform. No hardware cost shall be added for these enhancements (just the cost of the software/node module.)
 4. [In addition to the BASIC, ENHANCED and DEMAND metering the following HARMONICS metering package shall be provided. The values listed below shall be displayed on the equipment lineup HMI interface.
 - a. K factor for each current phase, Voltage Total Harmonic Distortion (VTHD) for each phase and Current Total Harmonic Distortion (ITHD) for each phase
 - b. Frequency spectrum (magnitude only) for each voltage and current phase up to the 31st harmonic. These values shall be graphically displayed as a bar graph on the equipment HMI interface.
 - c. As the Entellisis system provides the ability to move the HARMONIC metering package from breaker to breaker the following total number of HARMONIC metering packages shall be provided:
 - 1) Provide [One][Two][Three][Four][Five][Insert the number of HARMONIC metering packages] HARMONIC metering package for the lineup.
 - 2) The end user shall be able to move this package from breaker to breaker via the lineup HMI interface. If the provided metering devices does not have the ability to move from breaker to breaker, then ALL breakers MUST be supplied with the HARMONIC metering functions listed above
 - d. The GE Entellisis system shall provide the ability add additional HARMONIC metering packages to the lineup via a software/firmware platform. No

hardware cost shall be added for these enhancements [just the cost of the software/node module].

- L. The lineup [has no requirement for automatic transfer] [requires a three circuit breaker automatic throwover scheme and shall contain all the necessary instrumentation, status and control power requirements, etc. The interface for the status indication and the control of these devices shall be accomplished via the equipment lineup touch screen HMI.]
- M. The signaling/status information required on this project [will be provided via the system Ethernet communications interface.][will mostly be provided via the system Ethernet communication interface; however, as there is a need to provide some specific discrete signals, a digital I/O device shall also be incorporated into the lineup. Refer to the project drawings for the quantity of input and output signals.]
- N. As the GE Entellisys system [will function as a local unit, no additional HMI software shall be provided for remote functioning or viewing via a personal computer.][is required to allow for the exchange of information to a remote PC the following HMI software packages shall be supplied. This software shall be installed on a remote PC/laptop (installation and computer by others) and shall have the following functionality.
 - 1. If software is provided, it shall be the [FULL][VIEW ONLY] function software. The total quantity of software packages shall be [none][one][two].
- O. The following diagnostics tools shall be supplied in the equipment lineup.
 - 1. Standard sequence of event recording shall be provided. This feature will enable the user to view via the equipment HMI, any trip, alarm, logged event, etc. The system will have a unified time synchronization so that all recorded occurrences will be time stamped.
 - 2. The standard GE Entellisys tools [is all that is required for this project.][shall be supplemented the waveform capture enhancement. This feature will enable the user to view via the equipment HMI waveforms that triggered from a trip, an alarm or a manually initiation.]
- P. The GE Entellisys system will be provided with 3 (three) copper 10/100 Base T user ports (RJ-45 female receptacle) as standard. The communications protocol for the system will be an open architecture Modbus RTU/TPC-IP. [There is no need for any additional copper communication port(s).][In addition to the standard copper connection ports, a fiber external communication port shall be provided.]

- Q. As the equipment lineup will [function as a non-networked product, there is no Virtual Private Network (VPN) or firewall requirement.][have various network connections into and out of it for various monitoring, viewing, controlling, signaling, etc. capability; and as there is a need to restrict access into this communications environment, the manufacturer shall provide a Virtual Private Network (VPN) or firewall.]

2.07 GENERAL CIRCUIT BREAKER REQUIREMENTS

- A. The General Electric ANSI rated EntelliGuard product has been chosen as the basis of design given its robust metal frame construction and its ability for all parts to be replaced resulting in a service cost versus replacement cost impact to the user. Use of, or substitution by insulated case circuit breakers, molded case circuit breakers is unacceptable and will be rejected by the owner/engineer.

- B. Each breaker shall be a 3-pole electrically and mechanically trip free unit with self-aligning primary and secondary disconnecting contacts, arc quenchers, position indicator and the necessary hardware to mount on a drawout mechanism in the compartment.
- C. All circuit breakers shall be drawout type and the primary connections shall be fully silver plated copper-to-copper.
- D. For personnel safety considerations, it is preferred that a true closed door drawout mechanism be employed to permit the circuit breaker to be moved from the connected to disconnected position without opening the cubicle door. If closed door racking is not available, the manufacturer's quotation must note this exception to be considered as a possible acceptable alternative.
- E. The draw out mechanism shall provide four distinct positions: connected, test, disconnected, and withdrawn. An indicator shall be provided to show the position status. The cubicle door shall be able to close when circuit breaker is in the connected, test or disconnect position.
- F. Each circuit breaker compartment shall have grounded barriers at top, bottom, front and side. Furnish each compartment with draw-out rails and the necessary secondary control contact points.
- G. Padlocking provision shall permit locking the breaker in test and disconnected positions while in the cubicle.
- H. Grounding of breaker frame to the steel frame shall be maintained throughout travel of draw out mechanism.
- I. Each breaker cubicle shall be designed so that only the frame for which the cubicle was designed can be inserted. Devices of equal frame size shall be interchangeable.
- J. Manual or electrical closing mechanisms shall use an energy storage spring between the operator and the breaker contacts. This spring shall provide a constant closing speed not influenced by operator speed or control power voltage level.

2.08 MAIN OR MAIN-TIE-MAIN CIRCUIT BREAKER REQUIREMENTS

- A. The breaker frame and function shall be as detailed below:
 - 1. The breaker shall be [manually operated][electrically operated].
 - 2. The breaker application shall be per the details as shown on the project drawings.
 - 3. The breaker frame size shall be as shown on the project drawings.
 - 4. The breaker frame shall contain a minimum sensor rating of as shown on the project drawings.
 - 5. The breaker shall have a nominal breaker rating of the value as shown on the project drawings. This nominal setting shall be established via either a current setting rotary switch or a rating plug.
 - 6. The circuit breaker is [a non-fused style breaker][a fused style breaker with an open fuse lockout device].
 - a. If the breaker is fused, current limiting fuses shall be integrally mounted for 800 and 1600 ampere frame devices and separately mounted for 2000, 3200, 4000 and 5000 ampere frame devices. Separately mounted fuses shall be mounted inside a drawout carriage similar to that used for the breaker. A hinged panel of perforated steel shall be positioned in front of fuses to prevent

reaching them if the compartment door is opened. This panel shall be interlocked to prevent it from being opened unless the fuse rollout is fully withdrawn.

- b. If the breaker is fused, refer to the project drawings for fuse rating and class details.
- B. The breaker compartment shall be provided with the options / requirements detailed below:
 - 1. The compartment connection to the top shall be as shown on the project drawings.
 - 2. The compartment connection to the bottom shall be as shown on the project drawings.
 - 3. A Service Entrance label and lineup modifications [are][are not] required for the main device.
 - 4. The power flow through this device shall be as shown on the project drawings.
 - 5. The compartment door shall [be a standard compartment door][be provided with a defeatable compartment door interlock].
 - 6. As noted above in the EQUIPMENT OPTIONS – MECHANICAL section, drawout compartment shutters shall be used to protect operators from accidental contact with breaker stabs when the breaker is withdrawn from its cubicle. These shutter shall be provided on [only the Main and Tie breaker cubicles] [all breaker cubicles in the lineup].
 - 7. The compartment shall [not be a equipped with a position switch][be equipped with a position switch (2 form a and 2 form b contacts)][be equipped with a position switch (2 form a and 2 form b contacts) to signal the breaker position to the automatic throwover system].
- C. The breaker compartment cable connections shall be as detailed below:
 - 1. The feed direction of the cables shall as indicated on the project drawings.
 - 2. The neutral connection type shall be as indicated on the project drawings.
 - 3. The following types of cable lugs shall be supplied with the equipment:
 - a. The type of lugs shall be [compression lugs.] [clamp lugs (mechanical type).]
 - b. The supplied lugs shall be made of [copper][aluminum] and shall be manufactured by Burndy.
 - 4. The quantity and size of the cables shall be as described below:
 - a. The quantity of phase cables is as indicated on the project drawings.
 - b. The size of the phase cables is as indicated on the project drawings.
 - c. The quantity of neutral cables is as indicated on the project drawings.
 - d. The size of the neutral cables is as indicated on the project drawings.
 - e. The quantity of ground cables is as indicated on the project drawings.
 - f. The size of the ground cables is as indicated on the project drawings.
- D. The Entellisis system provides a wide variety of protective, signaling and control functions. Following are the specific requirements that must be supplied with the circuit breaker.
 - 1. LONG TIME protection shall be provided with adjustable PICKUP and DELAY.
 - 2. GROUND-FAULT protection [is not required on this project][is required as detailed on the project drawings].

- 3. The GROUND-FAULT function [must be non-defeatable as the equipment must be UL listed and labeled][shall be defeatable and be capable of being turned off].
- 4. SHORT TIME protection shall be provided with adjustable PICKUP and DELAY.
- 5. INSTANTANEOUS protection shall be provided with adjustable PICKUP. This function shall be a true adjustable with lo range settings (not with only high range or fixed high range).
- 6. To provide field coordination flexibility, both the SHORT-TIME and INSTANTANEOUS functions must be capable of being switched turned off via the HMI interface.
- 7. As the breaker is [manually operated no charging power is required.][electrically operated, the breaker closing springs will be charged via a spring charging motor. Control voltage/power of 120VAC @ 60 Hz shall be provided].
- 8. The breaker [is not required to perform any tripping functions other than the protective trips described above.][shall be capable of performing independent tripping functions. A 120VAC 60Hz shunt trip shall be provided].
- 9. The breaker [trip signaling shall come from standard network communications][shall be provided with a bell alarm with lockout to provide an additional signal that the breaker tripped].
- 10. The breaker [reclosing capability shall function in a normal fashion.][shall be provided with network interlock.].
- 11. As there is [no need to provide advance warning of breaker tripping, the high current alarm option is not required.][a need to provide a preemptive alert of the breaker tripping, the breaker shall be provided with the high current alarm option. The user adjustable pickup point shall send a signal when the breaker exceeds the established value.].
- 12. The breaker [will function in a normal utility mode] [shall be provided with a frequency and reverse power relay package].
- 13. The breaker [is not required to provide voltage sensing] [shall be provided with the voltage relay package].
- 14. The instrumentation configuration shall be as follows:
 - a. The CT configuration within the breaker cubicle shall be as indicated in the project drawings.
 - b. The CT power flow within the breaker cubicle shall be configured as indicated in the project drawings.
- 15. Key interlocking of the breaker [is not required on this project and should not be provided][is required as detailed on the project drawings].

2.09 FEEDER CIRCUIT BREAKER REQUIREMENTS

- A. The breaker frame and function shall be as detailed below:
 - 1. The breaker shall be [manually operated][electrically operated].
 - 2. The breaker application shall be per the details as shown on the project drawings.
 - 3. The breaker frame size shall be as shown on the project drawings.
 - 4. The breaker frame shall contain a minimum sensor rating of as shown on the project drawings.
 - 5. The breaker shall have a nominal breaker rating of the value as shown on the project drawings. This nominal setting shall be established via either a current setting rotary switch or a rating plug.
 - 6. The circuit breaker is [a non-fused style breaker][a fused style breaker with an open fuse lockout device].
 - a. If the breaker is fused, current limiting fuses shall be integrally mounted for 800 and 1600 ampere frame devices and separately mounted for 2000,

- 3200, 4000 and 5000 ampere frame devices.
Separately mounted fuses shall be mounted inside a drawout carriage similar to that used for the breaker. A hinged panel of perforated steel shall be positioned in front of fuses to prevent reaching them if the compartment door is opened. This panel shall be interlocked to prevent it from being opened unless the fuse rollout is fully withdrawn.
- b. If the breaker is fused, refer to the project drawings for fuse rating and class details.
- B. The breaker compartment shall be provided with the options / requirements detailed below:
1. The compartment connection to the top shall be as shown on the project drawings.
 2. The compartment connection to the bottom shall be as shown on the project drawings.
 3. A Service Entrance label and lineup modifications are not required for the feeder devices.
 4. The power flow through this device shall be as shown on the project drawings.
 5. The compartment door shall [be a standard compartment door][be provided with a defeatable compartment door interlock].
 6. As noted above in the EQUIPMENT OPTIONS – MECHANICAL section, drawout compartment shutters shall be used to protect operators from accidental contact with breaker stabs when the breaker is withdrawn from its cubicle. These shutter shall be provided on [only the Main and Tie breaker cubicles][all breaker cubicles in the lineup].
 7. The compartment shall [not be a equipped with a position switch][be equipped with a position switch (2 form a and 2 form b contacts)][be equipped with a position switch (2 form a and 2 form b contacts) to signal the breaker position to the automatic throwover system].
- C. The breaker compartment cable connections shall be as detailed below:
1. The feed direction of the cables shall as indicated on the project drawings.
 2. The neutral connection type shall be as indicated on the project drawings.
 3. The following types of cable lugs shall be supplied with the equipment:
 - a. The type of lugs shall be [compression lugs][clamp lugs (mechanical type)].
 - b. The supplied lugs shall be made of [copper] [aluminum] and shall be manufactured by Burndy.
 4. The quantity and size of the cables shall be as described below:
 - a. The quantity of phase cables is as indicated on the project drawings.
 - b. The size of the phase cables is as indicated on the project drawings.
 - c. The quantity of neutral cables is as indicated on the project drawings.
 - d. The size of the neutral cables is as indicated on the project drawings.
 - e. The quantity of ground cables is as indicated on the project drawings.
 - f. The size of the ground cables is as indicated on the project drawings.
- D. The Entellisys system provides a wide variety of protective, signaling and control functions. Following are the specific requirements that must be supplied with the circuit breaker.
1. LONG TIME protection shall be provided with adjustable PICKUP and DELAY.
 2. GROUND-FAULT protection [is not required on this project][is required as detailed on the project drawings].
 3. The GROUND-FAULT function [must be non-defeatable as the equipment must be UL listed and labeled][shall be defeatable and be capable of being turned off].
 4. SHORT TIME protection shall be provided with adjustable PICKUP and DELAY.
 5. INSTANTANEOUS protection shall be provided with adjustable PICKUP. This function shall be a true adjustable with lo range settings (not with only high range or fixed high range).
 6. To provide field coordination flexibility, both the SHORT-TIME and INSTANTANEOUS functions must be capable of being switched turned off via the HMI interface.
 7. As the breaker is [manually operated no charging power is required.][electrically operated, the breaker closing springs will be charged via a spring charging motor. Control voltage/power of 120VAC @ 60 Hz shall be provided].
 8. The breaker [is not required to perform any tripping functions other than the protective trips described above.][shall be capable of performing independent tripping functions. A 120VAC 60Hz shunt trip shall be provided].
 9. The breaker [trip signaling shall come from standard network communications][shall be provided with a bell alarm with lockout to provide an additional signal that the breaker tripped].
 10. The breaker [reclosing capability shall function in a normal fashion.][shall be provided with network interlock].
 11. As there is [no need to provide advance warning of breaker tripping, the high current alarm option is not required.][a need to provide a preemptive alert of the breaker tripping, the breaker shall be provided with the high current alarm option. The user adjustable pickup point shall send a signal when the breaker exceeds the established value.]
 12. The breaker [will function in a normal utility mode][shall be provided with a frequency and reverse power relay package].
 13. The breaker [is not required to provide voltage sensing] [shall be provided with the voltage relay package].
 14. The instrumentation configuration shall be as follows:
 - a. The CT configuration within the breaker cubicle shall be as indicated in the project drawings.
 - b. The CT power flow within the breaker cubicle shall be configured as indicated in the project drawings.
 15. Key interlocking of the breaker [is not required on this project and should not be provided][is required as detailed on the project drawings].

Notes

Entellisys Low-Voltage Switchgear Appendix B. Type Tests

The type tests to which the Entellisys system and/or the EntelliGuard Messenger have been tested include:

ANSI C37.90.1
ANSI C37.90.2
ANSI C37.20.2 Paragraph 5.3
ANSI C62.41
ANSI C84.1

IEC255-21-1
IEC255-22-5

IEC60255-6
IEC60255-22-1
IEC60255-22-6

IEC 60068-2-1
IEC 60068-2-2

IEC60947-1
IEC60947-2 sec. F.4.1.2
IEC60947-2 sec. F.4.2
IEC60947-2 sec. F.4.4
IEC60947-2 sec. F.7
IEC60947-2 sec. F.8
IEC60947-2 sec. F.9

IEC61000-4-4
IEC61000-4-5
IEC61000-4-8
IEC61000-4-9
IEC61000-4-11

EN61000-4-2

FCC part 15, subpart B, Class A

Notes

Entellisys Low-Voltage Switchgear

Appendix C. Standard and Optional Features

			Standard	Option
Architecture	HMI	Qty 1 mounted in lineup	✓	
		Redundant HMI in lineup		✓
		HMI in stand alone stack		✓
		HMI in wall mount cabinet		✓
		HMI in custom stand alone stack		✓
	CPU	Qty 2 mounted in lineup	✓	
	Control Power	Qty 1 CPT and throwover to user source (single ended)	✓	
		Qty 2 CPT's and throwover (double ended)	✓	
	UPS	Qty 2 in lineup	✓	
	Redundant Device Placement	Together in lineup	✓	
Separated locations in lineup			✓	
Protection	Messenger	1 per breaker cubicle	✓	
	Protection	O/C – LSI (switchable S or I – able to select LS, LI or LSI)	✓	
		Ground fault		✓
		Switchable GF (not UL listed)		✓
		Voltage package		✓
		High current alarm		✓
		Freq. & power package		✓
		Dynamic ZSI		✓
		Bus diff (DZSI included)		✓
		Low energy let-thru mode		✓
		High Resistance Ground Fault - detection only		✓
		Multiple source GF (for 4W systems with multiple sources)	✓	
		Metering & Diagnostics	Metering	Basic - A & V on all breakers
Expanded/detailed package				✓
Demand package (includes expanded package)				✓
Harmonics package (includes demand package)				✓
Diagnostics	Sequence of events recording		✓	
	System-wide waveform capture			✓
	Alarms (email capability)		✓	
Maintenance Information	Bkr indication for mech and elec life		✓	
Digital I/O and Control	Digital I/O		64 points - non-redundant	
		64 points - redundant		✓
		128 points - non-redundant		✓
		128 points - redundant		✓
	Control	Synch-check relay		✓
		Automatic throwover 2-breaker scheme		✓
		Automatic throwover 3-breaker scheme		✓
Communications & Accessories	External Communication	8 comm ports for external connection, copper	✓	
		9 comm ports for external connection, fiber		✓
		Firewall (located in lineup)		✓
		Remote viewer software		✓
		Remote user interface software		✓
		Access to external systems	✓	
		PMCS integration		✓
	Other Devices	Remote racking device		✓
		Test kit		✓

Notes

Entellisys Low-Voltage Switchgear Appendix D. Time Current Curves

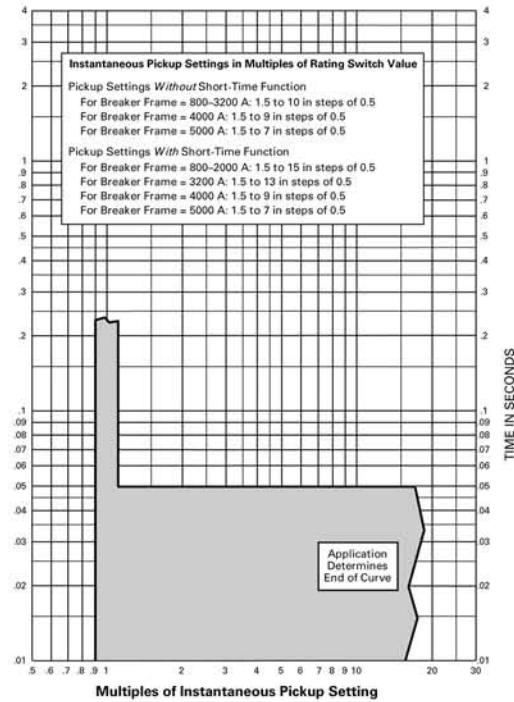
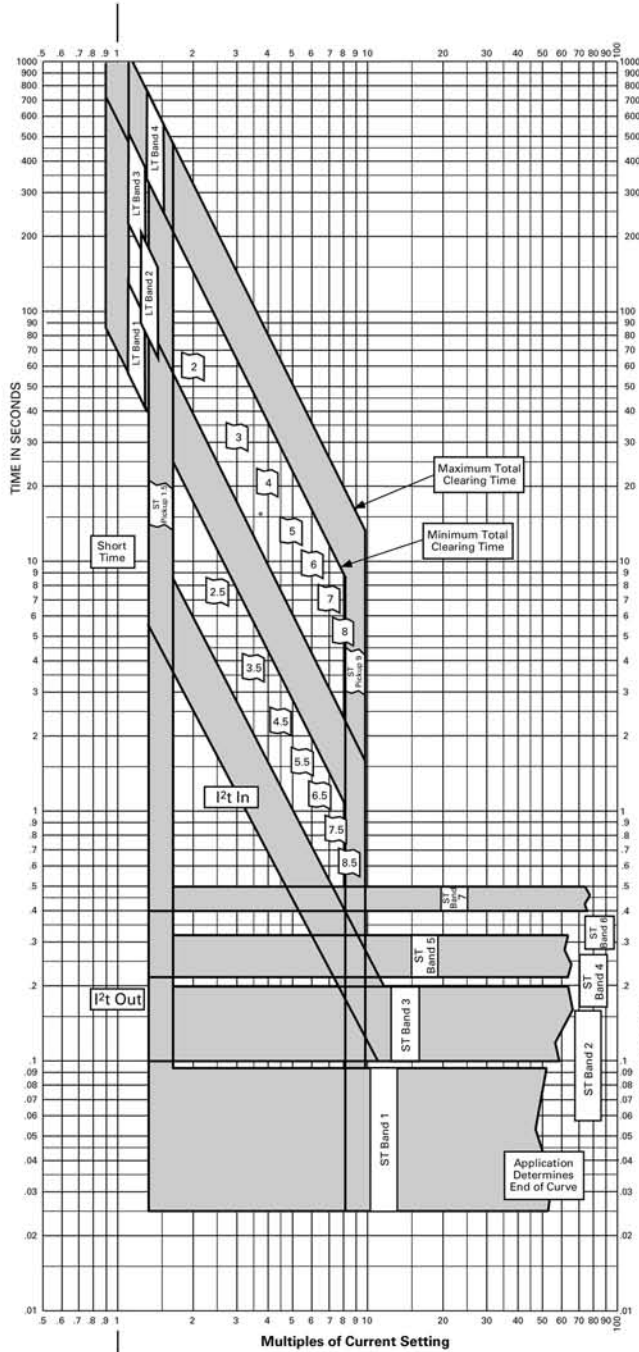

GE Consumer & Industrial
General Electric Company
41 Woodford Avenue, Plainville, CT 06062

Entellisys™ Low-Voltage Switchgear with Entelliguard™ Low-Voltage Power Circuit Breakers

DES-032

Time Overcurrent Protection

Adjustments

Long-Time Pickup and Delay Short-Time Pickup and Delay Instantaneous Pickup

- Long-Time Function:**
- Long-time setting multipliers: 0.5 to 1.1 in 0.05 increments and are multiples of the rating switch setting amps.
 - Delay bands: 1, 2, 3, and 4
- Short-Time Function:**
- Pickup settings: 1.5 to 9.0 in 0.5 increments and are multiples of the current setting.
 - Delay bands (I²t In & Out): 1 = Min, 7 = Max
- Instantaneous Function:**
- See table and curve above.

Available Ratings (Amperes)

Breaker Type	Model	Frame	Current Sensor	Rating Switch Setting, A
LVPCB	EG08	800	150	60, 80, 100, 125, 150
			400	150, 200, 225, 250, 300, 400
	EG16	1600	800	300, 400, 450, 500, 600, 700, 800
			1600	600, 800, 1000, 1100, 1200, 1600
	EG20	2000	2000	750, 800, 1000, 1200, 1500, 1600, 2000
	EG32	3200	3200	1200, 1600, 2000, 2400, 2500, 3000, 3200
	EG40	4000	4000	1600, 2000, 2500, 3000, 3200, 3600, 4000
	EG50	5000	5000	3200, 4000, 5000

Note: I²t slope is selectable only for short-time bands 3, 4, 5, 6, and 7. Bands 1 and 2 cannot have the I²t slope applied to them.

Voltage Rating: 600 volts ac, nominal

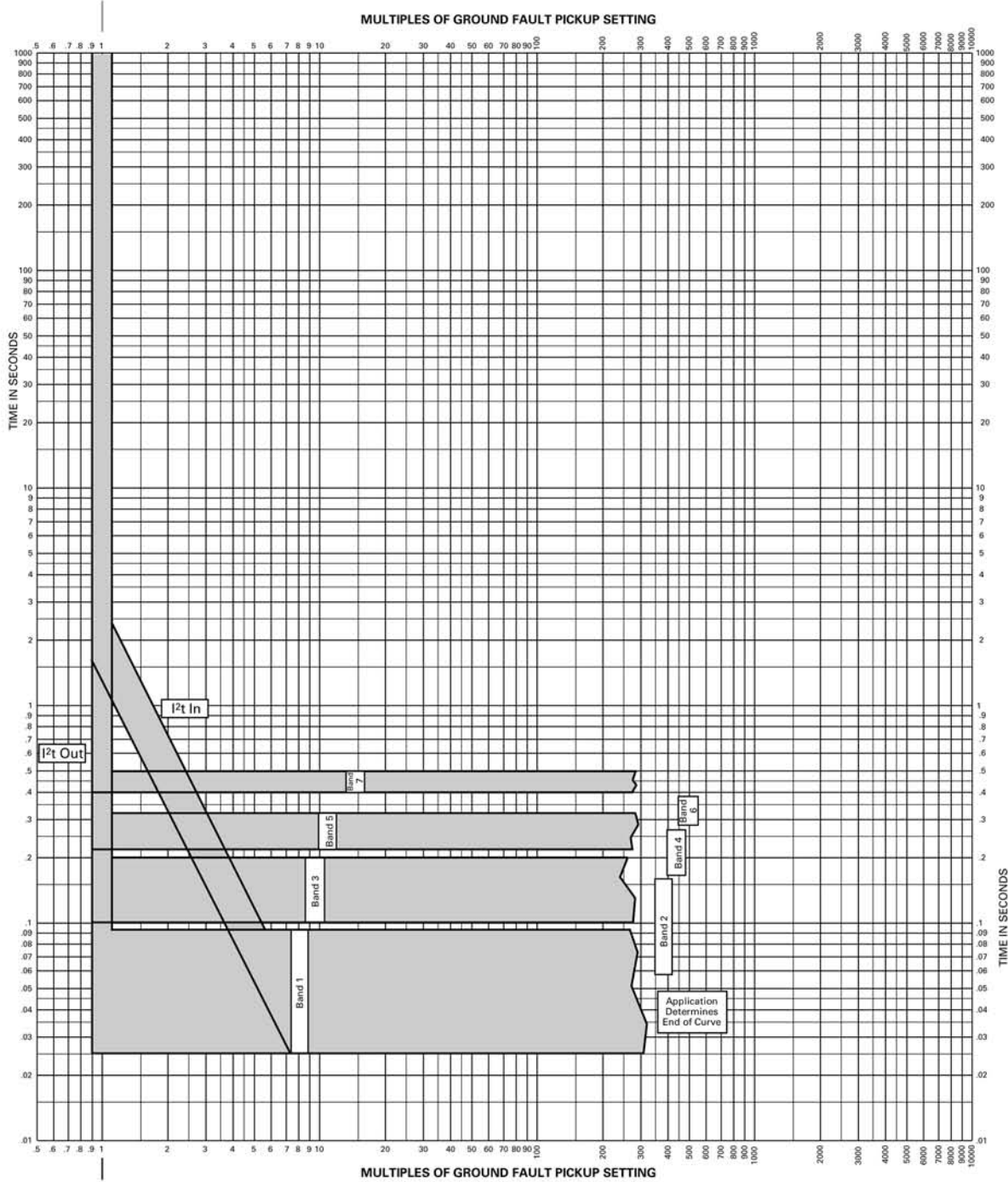

GE Consumer & Industrial
 General Electric Company
 41 Woodford Avenue, Plainville, CT 06062

Available Ratings (Amperes)

Frame	Current Sensors
800	150, 400, 800
1600	800, 1600
2000	2000
3200	3200
4000	4000
5000	5000

Voltage Rating: 600 Vac, nominal

Entellisys™ Low-Voltage Switchgear with Entelliguard™ Low-Voltage Power Circuit Breakers

Ground-Fault Pickup and Delay

DES-033

Ground Fault Function: Pickup settings in multiples of Current Sensor Rating

Sensor, I_{CT}	Pickup Settings in Increments of .01
150-2000	2-6
3200	2-37
4000	2-3
5000	2-24

Note: Ground fault for multiple-source systems follow this curve; however, the curves are calibrated in amperes, not multiples of any one circuit breaker, and will apply equally to all source circuit breakers in the zone. Maximum setting for a zone will be 1200A and the minimum will be 20% of the largest sensor defined as a source for the zone.

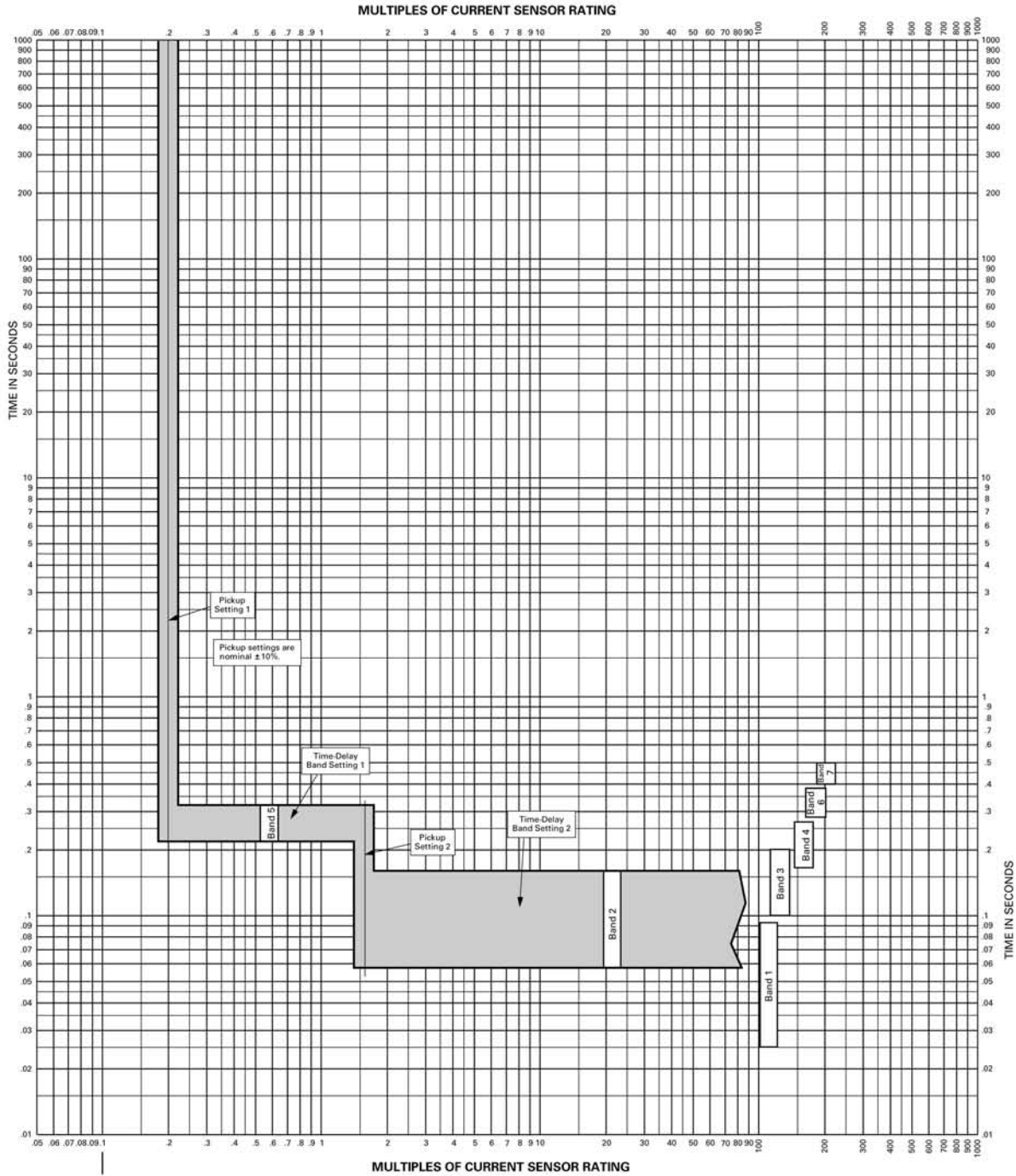

 **GE Consumer & Industrial**
 General Electric Company
 41 Woodford Avenue, Plainville, CT 06062

**Entellisys™ Low-Voltage Switchgear with
 Entelliguard™ Low-Voltage
 Power Circuit Breakers**

Bus-Differential Protection Applied to Zones

Pickup 1, Time Delay 1, Pickup 2, Time Delay 2

DES-034

- Adjustment Notes:**
1. Pickup 2, if used, must be > pickup 1; time delay 2 must be ≥ time delay 1.
 2. Bus-differential pickup adjustment range is from minimum of 0.2 of the largest sensor in the zone to a maximum of 22,000 A.
 3. Bus-differential function will pick up when the calculated fault current exceeds the pickup threshold for the zone as long as the current for any one circuit breaker within the zone does not exceed 10 times the sensor rating for that circuit breaker.
 4. It is recommended that bus differential be used in conjunction with zone selective interlocking for full fault range zone based protection.
 5. Bus-differential pickups are continuously adjustable and calibrated in amperes.

Notes

Information contained in this application guide is based on established industry standards and practices. It is published in the interest of assisting in the preparation of plans and specifications for low-voltage switchgear. Neither the General Electric Company nor any person acting on its behalf assumes any liability with respect to the use of, or for damages or injury resulting from the use of any information contained in this application guide.

GE Consumer & Industrial
Electrical Distribution
Switchgear Equipment
510 East Agency Road
West Burlington, Iowa 52655

© 2005 General Electric Company
www.geelectrical.com

